

DOI: <https://doi.org/10.15276/aait.04.2020.3>

UDC 004.942:621.923

**COMPLEX-SHAPED PARTS GRINDING TECHNOLOGY
INFORMATION ENSURING****Vasily P. Larshin¹⁾**ORCID: <https://orcid.org/0000-0001-7536-3859>, vasilylarshin@gmail.com**Natalia V. Lishchenko²⁾**ORCID: <https://orcid.org/0000-0002-4110-1321>, odeslnv@gmail.com¹⁾Odessa National Polytechnic University, 1, Shevchenko Ave., Odessa, 65044, Ukraine²⁾Odessa National Academy of Food Technologies, 112, Kanatna St., Odessa, 65039, Ukraine**ABSTRACT**

A method of computer-aided design and manufacture of complex-shaped parts of machines and implants from difficult-to-machine materials (titanium, cobalt-chromium alloys, zirconium dioxide, etc.) has been developed, based on the principles of building an integrated CAD/CAM/CAE system of computer-aided designing and a hierarchical intelligent numerical control system. It is shown that kinematical mechanisms created over the past several centuries do not allow reproducing with the required accuracy the joints movement of living organisms for their use in biomedical implantation technologies. Therefore, the worn out joints of living organisms are reconstructed by adding complex-shaped parts from these difficult-to-machine materials. Information about the geometric shape of these parts (3D model) at the pre-production stage is obtained using modern methods of computed tomography and magnetic resonance imaging, and at the production stage the actual location of the stock grinding allowance is measured by laser (or tactile) scanning. To reduce the unevenness of the position of the grinding stock allowance, the workpiece of a complex-shaped part before grinding is oriented in the coordinate system of a CNC machine based on the established criterion for minimizing the allowance. An example of such orientation of the gear workpiece is given. This workpiece is measured with a Renishaw tactile probe on the left and right sides of the gear valleys before gear grinding. Both the minimum allowance on the left and right sides of the valleys and the difference between them are determined, and then additionally the gear wheel blank is rotated in the appropriate direction to align these minimum values detected. In turn, the aligned minimum allowances, should be sufficient to compensate for the influence of technological factors from the previous operation and the error in setting the workpiece for this operation. For complex-shaped implants, such an additional orientation is performed, for example, according to algorithms for ensuring the minimax value of the allowance.

Keywords: Grinding; Implants; Designing; Monitoring; Diagnosing; Grinding Wheel

For citation: Vasily P. Larshin, Natalia V. Lishchenko. Complex-Shaped Parts Grinding Technology Information Ensuring. *Applied Aspects of Information Technology*. 2020; Vol.3 No.4: 246–262. DOI: <https://doi.org/10.15276/aait.04.2020.3>

INTRODUCTION

Parts of modern machines and mechanisms, as a rule, are a combination of the following external and internal “elementary surfaces”: planes, cylindrical, conical, threaded, toothed, and other surfaces. This is due to the functional features of these parts during their operation, namely the combination of linear and rotary movements. In turn, the numerous available metal-cutting machines that have gone through a long evolutionary period of development, no matter what machine we take (turning, milling, drilling, etc.), they are all designed for mechanized and automated mutual movement of the tool and workpiece along elementary trajectories (and/or their combinations). The above “elementary surfaces” also differ in complexity. For example, toothed and threaded surfaces contain grooves or gaps described by curves of the second order (threads) or trigonometric functions (tooth involute). As a rule, such trajectories are specified either by a

complex profile of the cutting tool with its simple kinematic movements (copying method), or by a complex trajectory along which a tool with a simple shape moves (rolling method).

The development of biomedical implantation technologies has made the task of making so-called restoration structures (assembling units) consisting of several parts. There are many articulations (joints) in living organisms: knee, hip, shoulder, wrist, temporomandibular, spine, etc. They are all subject to aging and wear. Human upper and lower jaws are filled with teeth which have different geometric shapes. They also wear out and need to be restored. For example, a dental implant with a crown attached used for a single tooth replacement. It contains an implant itself of titanium alloy, an abutment of plastic (as an adapter), and a complex-shaped form crown of zirconium dioxide. In this sequence of parts, the first two (implant and abutment) may be in the form of machine parts, while the third (crown) has a complex shape due to the tooth function (functionality) in a living organism, namely biting, chewing, aesthetics, etc. At the same time, the manufacturing and assembly technology is fully

© Larshin V., Lishchenko N., 2020

This is an open access article under the CC BY license (<https://creativecommons.org/licenses/by/4.0/deed.uk>)

consistent with that adopted for the manufacture of parts, mechanisms and machines.

Any technology has the pre-production (process design), production itself (process implementation) and post-production (testing and maintenance) stages. For example, the pre-preparation stage corresponds to the surgical operation planning, the production stage – to the main medical (surgical) procedures, and the post-production stage (testing and recovery) corresponds to the healing stage in biomedical implantation technology. To the present, the specified stages of the product life cycle are automated and performed within the integrated system “Computer-Aided Design, Computer-Aided Manufacturing, and Computer-Aided Engineering” (hereinafter CAD/CAM/CAE).

The complexity of implant surfaces is due to the functional difference between machine parts (machine elements) and natural origin components, which evolved in living organisms for millions of years before taking on modern forms that have been worked out by nature.

Modern implantology, introducing new technical constructions when replacing natural biological structures (for example, self-tapping screws, pins, etc.), at the same time uses constructive forms developed by nature as a basis, for example, the hip and knee (Fig. 1) joint constructions.

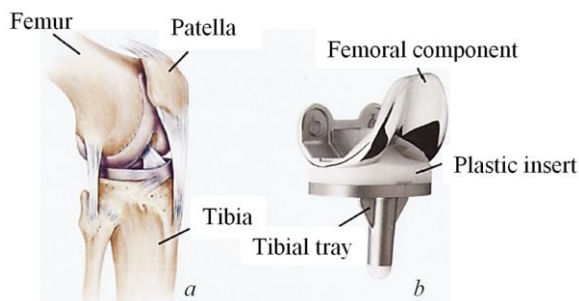

Fig. 1. The normal anatomy of a human knee (a) and an orthopaedic femoral implant unit (b)
[Source: De Puy, Johnson & Johnson]

Implants are made from materials that are difficult to machine; they, as well as machine parts, operate under conditions of high specific loads and are prone to wear. That is why, difficult-to-machine metals and alloys are used for implants, for example, titanium alloys, cobalt-chrome ones, alloyed steel, zirconium dioxide, etc.

Among other things, mechanical engineering technology includes abrasive machining for generation of the so-called complex-shaped part surfaces such as impeller’s blade, lead screw & nut thread, gear, and others surfaces, which are similar

in complexity to the biomedical implant surfaces. These technical parts to be machined are referred to the complex-shaped parts and may be used both in machine-building, aviation, and biomedical industries, etc. At every point of the contact zone the grinding stock allowance changes as well as the depth of cut, the material removal rate, etc. This, in turn, leads to the grinding specific energy changing, as well grinding power, mechanical vibration, etc.

During both the implants and machine parts finishing machining, which are made of difficult-to-machine materials, the same technological difficulties arise. For example, increased local temperatures in the cutting and grinding zone lead to the structural and phase changes in the surface layer – grinding burns and cracks. The tempering burns reduce both the hardness of the ground part material and the part life as well. Secondary hardening burns violate the part surface integrity. They are unacceptable to the same extent as the tempering burns.

These defects (burns and cracks) lead to the increased joint wear during its running and even its failure. In this regard, the problem of developing a defect-free technology for grinding the working biomedical implant surfaces is urgent scientific problem.

To solve this problem, it is necessary to determine the current temperature in the grinding zone and limit its maximum value due to the correct choice of grinding parameters. That is why the temperature in the grinding zone is one of the main factors limiting the grinding performance. Grinding temperature mathematic models are needed for the designing and monitoring the grinding operation to boost the operation throughput. This is fully relevant, for example, for complex-shaped parts of the biomedical assembly unit. Once this technological problem is solved, it becomes possible to develop appropriate computer subsystems to optimize and control the grinding operation grinding machines with computer numerical control (CNC) at the pre-production and production stages.

Thus, to increase the complex-shaped parts grinding productivity while ensuring the specified grinding accuracy and quality it is necessary to find technological resources and ways. One of the ways is the designing, monitoring, and diagnosing subsystems development which may be a part of an intelligent numerical control system and performs the process disturbance detection and process optimization.

1. LITERATURE REVIEW

The difference between technical mechanisms and mechanisms of natural origin becomes clear

from a comparison of the models of these mechanisms. For example, in work [1], three kinematic diagrams are shown using a planetary mechanism (Fig. 2), a four-bar hinged mechanism (not shown here) and a two-slide mechanism (not shown here).

The known technical mechanisms only approximately reproduce the movements of the living biological organisms joints, since each of them only approximately provides the condition for the closing link $\delta = \text{const}$ (Fig. 2).

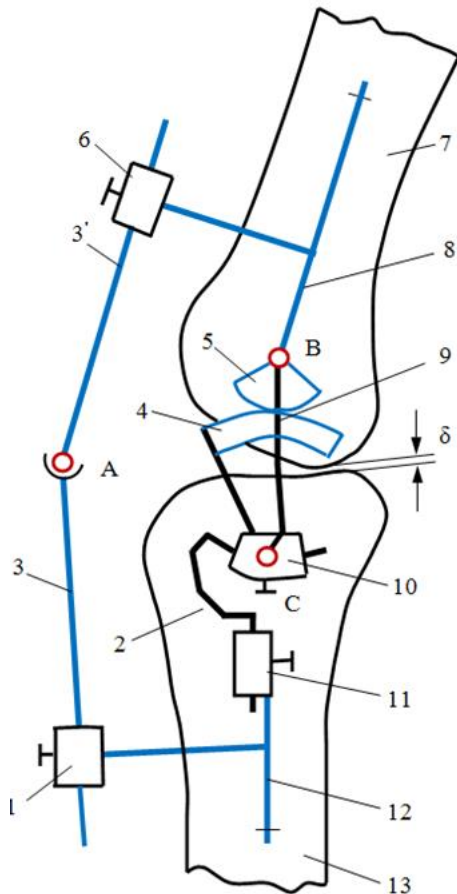

Fig. 2. Artificial joint: δ is the closing link of the mechanism [1]

Source: [1]

Link 8 (Fig. 2) is attached with special spokes to the femur 7 and link 12 – to the tibia 13. Links 8 and 12 are located outside the joint. Rigidly meshed gear sectors 5 and 4 is attached to links 8 and 12; the link 5 – to the link 8 and the link 4 – to the link 12. To ensure continuous engagement of the sectors 5 and 4 and for the constancy of the distance between their axes, these axes B and C are connected by link 9. The position of sector 4 is adjusted by moving the slider 10 relative to link 2 and by moving the link 2 in the guide 11 of the link 12.

Adjustment of the amount of “bending and unbending” of the mechanism is carried out by

changing the length of the rods 3 and 3', moving them in the guides 1 and 6, respectively. The rods are interconnected by a spherical hinge, and the guides 1 and 6 are rigidly attached to the links 12 and 8, respectively. The points of the articular surface of the tibia move along a cycloidal curve, which only approximately corresponds to the natural trajectory of movement.

The difference in the shape of the working surface of the joints from the elementary geometrical one and the combination of elementary surfaces lead to the need for freeform abrasive machining [2] with standard cutting tools that work using well-known methods of copying and rolling. In this regard, a number of problems arise. Firstly, there is a need for preliminary orientation of the blank of a complex-shaped part to reduce the unevenness of the position of the grinding stock to be removed. Secondly, it is necessary to choose the most suitable cutting tool, including the geometric shape and characteristics of the grinding wheel, which makes it possible grinding the surface of the implant blank made of difficult-to-machine material, i.e., freeform surface. Further, the tasks of technological process and operations design arise including grinding operations. There is a known method of preliminary orientation of the complex-shaped part blank according to the criterion of the so-called minimax. Fig. 3 shows the position of the workpiece 1 and the part to be machined 2 in the original machine coordinate system when designing the control program in the CAM system [3].

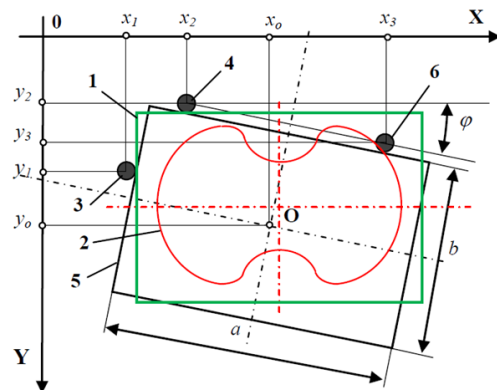

Fig. 3. An example shows the search for the initial orientation of the workpiece [3]

Source: [3]

To bind the workpiece according to the traditional technology, it is location in the coordinate system so that a strict orientation is observed with respect to the machine guides using a special device. In this case, the actual position of the workpiece (binding of the control program) is determined by the coordinates of two dimensions: point 3 and point 4. If the workpiece is installed on the machine

without aligning its position and without a special device, it may turn out that its actual position does not ensure milling contour, since the control program corresponds to a position of the detail that extends beyond the workpiece.

In order to allow machining of the part contour specified by the program and to fulfill the requirement of preserving the originally designed distribution of the allowance, it is necessary to set the coordinates of the offset of the control program along two coordinate axes and the rotation angle. Thus, the problem is reduced to the solution of the minimax problem: to find such a location of the part (control program) in the workpiece (its actual position), so that the maximum distance between the contour of the part and the workpiece is minimal. In this case, it is necessary to fulfill the following constraint: the entire part is located in the workpiece and does not go anywhere beyond it.

In work [4], based on the analysis of works [5, 6], [7], it is proposed grinding the arbitrary surfaces (or freeform surfaces) of implants on the basis of monitoring the grinding system state.

Orthopaedic total knee replacements typically comprise a cobalt chrome femoral head component which articulates on a low-friction polyethylene platform resting on a cobalt chrome tibial tray (Fig. 1b). Such components are subject to high dimensional quality standards in order to ensure minimum wear and efficient transfer of load through the articulating surface when in vivo [5]. A multiple axis abrasive machining operation with electroplated toroidal-shaped CBN wheels is used for generation of the surface of the cobalt chrome femoral component.

Such machining operations are often inefficient due to conservative choices of machining parameters which are based upon trial-and-error approaches in order to maintain workpiece surface integrity. Process monitoring can increase the performance and efficiency of machining through avoidance and compensation for process disturbances while information regarding the measured process quantities obtained with the monitoring system can also be used for optimizing the process [6, 7]. Femoral component in Fig. 4 has complex-shaped working surface which according to work [4] can be referred to the so-called freeform (arbitrary) surface.

The work [4] notes that modern machine control systems allow open access to internal signals in the numerical controller providing the opportunity to measure and record these signals via the human-machine interface.

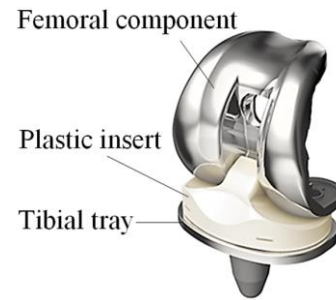

Fig. 4. An example shows an orthopedic femoral implant

Source: <https://www.medicaexpo.ru/prod/depuy-synthes/product-79814-790762.html>

Recording of internal machine signals is a promising technique for process monitoring without unwanted interference within the machining envelope or structure and significant information can also be obtained from the power consumption of a spindle in a cutting process [8, 9]. Further, the authors of the work [4] describe the so-called position-oriented process monitoring in freeform abrasive machining including both engagement and specific energy analysis.

However, work [4] does not say anything about the initial orientation of the workpiece before processing and how to use the information obtained to ensure effective grinding of a complex surface. For example, nothing is said about the grinding temperature. Although it is known that the determination of the specific work can be used to indirectly measure the grinding temperature and build the topography of the position-oriented temperature field.

The positive qualities of the work [4] include the choice of the geometric shape (toric) and the grinding wheel (Fig. 5) characteristics (i.e., specifications).

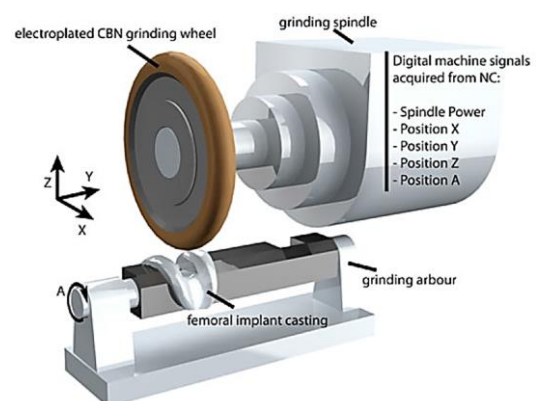

Fig. 5. Femoral implant machining setup and internal machine signal acquisition [4]

Source: [4]

The design stage of the implant processing technology is critical and has a significant impact on the quality of the surgical operation, reducing the risk of possible complications. In this regard, CAD/CAM/CAE design technology is part of the development of a unified intelligent control system. To some extent, the beginnings of the intelligent systems theory had been developed by Saridis and his scientific school [10]. The Saridis' theory may be thought of as the result of the intersection of the three major disciplines, namely (1) artificial intelligence, (2) operations research, and (3) control theory. The control intelligence is hierarchically distributed according to the so-called "principle of increasing precision with decreasing intelligence" or IPDI principle. Therefore, the Saridis' management has a hierarchical structure and the accuracy of achieving the result increases when moving from the top level to the bottom one. At the top level, for mechanical engineering area a fundamental technology is developed. It includes, e.g., the choice of shaping method, corresponding equipment, tooling, machining parameters, etc. At the bottom level, the fundamental technology obtained at the top level could be adjusted to take into account the individual characteristics of the components of the technological (i.e., process) system, but up to date there are no appropriate mechanisms for this.

Such, hitherto not developed management corresponds to the way of the economy called by "Industry 4.0" in which the so-called CAD/CAM/CAE integrated system trend is now the state of the art scientific trend [11,12], [13, 14], [15].

In the final part of the review, an analysis of the technology of multi-axis profile grinding on computer numerical control (hereinafter CNC) machines [16,17], [18,19] is carried out. The state of the art on determining the grinding temperature is analyzed. The existing possibilities of preliminary design of grinding operations and the subsequent implementation of these operations on CNC machines are shown. Some scientists have attempted to determine material removal rate for complex parts. Specific material removal rate was calculated for five-axis grinding in a virtual machining simulation environment [20].

For achieving high material removal rates while grinding free formed surfaces, shape grinding with toroid grinding wheels is favored. The contact area between grinding wheel and workpiece is complex and varying [10]. Without detailed knowledge about the contact area, which is influenced by many factors, the shape grinding process can only be performed sub-optimally. To improve this flexible production process and in order to ensure a suitable process strategy a simulation-tool is being

developed. The simulation comprises a geometric-kinematic process simulation and a finite elements simulation. This paper presents basic parts of the investigation, modelling and simulation of the NC-shape grinding process with toroid grinding wheels.

The technical review [21] gives an overview about state of the art of five-axis grinding and presents results, which can close some scientific lacks. Models were developed to predict the surface roughness and material removal dependent on the process parameters. Additionally, the relationship between tool geometry, shape accuracy as well as contact conditions is discussed. The complexity of the tool path generation requires the use of computer-aided design/computer aided manufacturing (CAD/CAM) systems.

There are two approaches to determining the grinding temperature. The first approach is the phenomenological one based on the Fourier differential equation of the thermal conductivity; this is analytical method of temperature determination [22, 23]. The second approach is the temperature field computer-aided simulation by the method of finite elements (FEM simulation) [24, 25].

The following monitoring functions are noted in grinding [26]: positioning of the grinding wheel, which is being balanced, relative to the workpiece; optimization of the stock removal by the grinding wheel taking into account its wear; the wheel overload control during workpiece processing and the wheel maintenance; positioning the grinding wheel relative to the dressing device; optimization of the dressing process. To do so, the grinding machines are equipped with sensors for cutting forces, spindle power, vibration, acoustic emission, etc. The measurement results are collected and analyzed to assess the characteristics both of the grinding system state and the grinding wheel.

Acoustic emission sensors are used to prevent collisions, detect machine faults, chipping or surface defects of the grinding wheel, and defects of the control device [27, 28], [29].

The sensors are easily integrated into the machine for the following purposes:

- 1) controlling the grinding wheel approach to a workpiece and unprogrammed stops of the machine;
- 2) air gap control, in which the acoustic emission sensor detects the distance between the grinding wheel and the workpiece;
- 3) dressing control;
- 4) checking the size and positioning.

The sensors are located at the points of the main emission of the signal, do not interfere with the rotation of the workpiece, which is positioned and measured.

It is noted that the grinding power can be used to reduce unproductive “grinding of air”, to prevent spindle overload and collision detection [30].

The possibility of using the acoustic emission signal to prevent grinding burns is noted in [6]. By means of neural networks the dimensionless size of a grinding scorch (burn) is formed. Burns are detected when the specified dimensionless value of the burn is exceeded. But unlike the power signal, the acoustic emission signal is an integral characteristic and this limits the use of acoustic emission sensors to diagnose burns with uneven allowance distribution.

The power of profile grinding was measured in the “on-line” mode [31]. In this case, the calculated limit value of the power at which the burn appeared on the ground surface was previously calculated. The afterburning was determined by the Barkhausen method when the power limit was exceeded. The disadvantage of this approach is that the data on the power limit values meet certain processing conditions, it is not clear how the formula for determining the grinding power limit value is obtained, the number of grounded gears is not specified to establish the relationship between the root mean square value (quadratic mean) of the Barkhausen signal. In work [32], a portable power monitoring system with specially designed grinding analytical software was developed. The main software modules included signals acquisition, feature extraction and data calculation (grinding energy consumption and proportion included), and data analytical toolkit. Knowledge-based analytical tool was established through the correlation between grinding power/energy and grinding conditions.

Real-time true power signals were monitored in a designed display window, which were also recorded in the storage file for further data extraction, calculation and analysis. Grinding peak power was plotted in a digital indicator, in which pre-warning peak power limit was manually set. Alert information (or alarm) will be generated when the grinding peak power exceeds the limit. This is able to prevent overload of the main spindle and detect collisions during grinding operations.

The application of the developed power (energy) monitoring system and this model allows for the prediction of grinding regimes in which undesired burning can be avoided based on energy considerations. Furthermore, critical grinding conditions can be deduced to avoid grinding burns.

The dependences of grinding power and specific grinding energy on material removal have been investigated. Specific grinding energy, which is measured in J/mm^3 , is energy consumption per unit of material removal.

Large specific grinding energy indicates more energy consumption of material removal and worse performance of grinding wheel. Grinding wheel with higher specific grinding energy usually results in grinding burn (or high grinding temperature) and small G-ratio (the ratio of the volume of material removed to the volume of wear of the grinding wheel). It is an indicator to distinguish wheel performance.

The application of the developed power (energy) monitoring system and this model allows for the prediction of grinding regimes in which undesired burning can be avoided based on energy considerations.

Estimation of specific energy consumption is a good indicator to control the consumed energy during the grinding process is noted in work [33]. Consequently, this study develops a model of material-removal rate to estimate specific energy consumption based on the measurement of active power consumed in a plane surface grinding of C45K with different thermal treatments and AISI 304. The specific energy consumption decreases with increasing material removal.

Thus, to monitor the process of grinding a complex profile, it is advisable to measure the cutting power, since it is characterized by changing conditions of grinding at each point and predetermines the temperature field causing thermal damage.

Knowing the grinding power and position signals, it becomes possible to determine the specific energy parameter, heat flux density, and, therefore, the temperature at each point of a complex profile.

Literature review showed that biomedical implantology has a large number of unsolved problems and emerging difficulties associated with the manufacturing technology and finishing of implants from difficult-to-machine materials, namely titanium alloys, cobalt-chrome ones, alloyed steel, zirconium dioxide.

The review shows that there is no information about the current grinding temperature in the existing computer systems for monitoring and process diagnostics on CNC grinding machines. This is due to the difficulty of measuring this parameter directly or at least indirectly. Therefore, to increase the productivity of the complex-shaped parts grinding while ensuring the specified accuracy and quality of processing it is necessary to find technological resources and ways to use the resources effectively which can be done on the basis of monitoring system which may be a part of an intelligent numerical control system and performs the process disturbance detection and process optimization.

The paper is referred to the area of technological processes and systems automation. At present, intelligent numerical control is the highest level of automation (after adaptive control). However, there is still no theory of intelligent systems that could be applied in mechanical engineering technology.

Abrasive machining is used for the generation of freeform part surfaces such as impeller's blade, lead screw thread, gear, biomedical implants, etc. These parts to be machined are referred to the complex-shaped parts and are used in machine-building, aviation, biomedical industries, etc. At every point of the contact zone the grinding stock allowance changes as well as the depth of cut, the material removal rate, etc. This, in turn, leads to the grinding specific energy changing, as well grinding power, mechanical vibration, etc.

Nowadays, the computer-aided designing, monitoring, and diagnosing are the means increasing the productivity of the grinding operation especially when complex-shaped parts grinding. This is the bottom level of the intelligent control mentioned according to the Saridis principle.

It was found that the mentioned finishing processing is performed on CNC machines with at least five controllable coordinates, which is associated with the need to orient the workpiece to ensure the relative position of the complex-profile workpiece of the implant to be ground and the grinding wheel. Since the grinding wheel has a certain diameter to ensure the cutting speed, on the one hand, and its contact with the workpiece has a certain extent (not a point), on the other hand, the most rational is the toroidal surface of the grinding wheel, which changes its position in relation to the complex-profile surface of the workpiece. The mutual position of the wheel and the workpiece is controlled simultaneously along several coordinates. The number of such coordinates, as a rule, does not exceed six degrees of freedom of the workpiece in space. There is a certain analogy in the complexity of positioning the implant with a similar complexity of movements during processing, for example, of the blade of a gas turbine engine on a multi-axis machining center with a spherical cutting surface of an end mill. As for the scheme of machining with a toroidal surface of a grinding wheel during position-oriented machining, in this case there is an analogy with the machining scheme by ball end mill.

Analytical solutions, according to the first approach, require some assumptions and do not allow accounting both the variable heat flux along the complex shape and the geometric shape with its dimensions, curvature, etc. Since each point of a complex profile is characterized by an individual

instance allowance, therefore, a temperature field at each point is characterized by an individual heat flux density (the second kind boundary condition). Besides, the temperature field at each point is influenced by the adjacent points of the profile.

The FEM simulation method, according to the second approach, is used to determine the temperature field in profile grinding taking into account even the forced cooling, movement of the contact area, variable heat flux along the complex shaped, surface geometric shape, etc.

It is obvious that the first approach (analytical) has an advantage since it requires less time for the decision making. The second approach (FEM simulation) is more laborious and can be used to justify the first one.

Efficiency of the abrasive machining process can only be achieved if a suitable process monitoring platform is available in order to process disturbance detection and process optimization.

The use of CNC software control systems with an open architecture allows the monitoring function from the CNC controller to be realized. The use of modern grinding wheels with self-sharpening abrasive materials (mono-corundum, sol-gel corundum, ruby corundum) is another reason for automatic control of the machining process using a monitoring system. These wheels, as well as CBN wheels are valuable and must be used effectively.

The relevance of the monitoring the grinding process is due to the receipt of tight tolerances and high-quality surface characteristics, it is ground with high-performance machining the parts of difficult-to-cut materials (titanium alloys, cobalt-chrome alloys, alloyed steel, etc.). Moreover, the monitoring system may be connected in series to the CAE block. Then CAE is received the possibility of adjustment (training) taking into account the real results of monitoring and control (intermediate and final), which is performed on a working metal-cutting machine.

2. RESEARCH METHODOLOGY

The analysis of literary sources made it possible to identify the following methodological issues related to the development of grinding technology for complex-shaped surfaces.

1. The choice of technological equipment and accessories (fixtures, cutting, measuring and auxiliary tools), which allow providing physical access to all points of the complex surface being ground, as well as the ability to obtain information about the initial and current position of this surface.

2. Solving the problem of the initial setting and basing of a complex-shaped part in the machine

coordinate system based on minimizing the unevenness of the grinding stock allowance position.

3. Determination of grinding parameters taking into account the actual location of the allowance on a complex-profile part.

4. Control (testing) of the part after grinding directly on the CNC grinding machine using the built-in measuring system and selective control on more accurate measuring equipment, for example, on a coordinate measuring machine (CMM).

The fundamental solution to the problem of computer-aided design and production in accordance with intelligent numerical control at the production stage involves the use of an integrated CAD/CAM/CAE system. Let's introduce some definitions. Firstly, a process as a technical and technological system is a set of elements that are located in time, i.e., in a time sequence of ordered actions, e.g., the sequence of operations, operation steps, working passes, etc. Secondly, a technological system is a construction (space structure), i.e. not a process, that is assembled by a technologist for the technological process (operation) duration. This structure (as a technical system-construction) is a collection of elements that are located in space (machine, fixture, cutting tool, workpiece).

The modern understanding of CAD/CAM/CAE automation is considered taking into account the product life cycle, which contains a number of time stages, including product design (CAD), process design (CAM), and process systematic engineering calculations (CAE) with special computer software packages, as well as the product testing and the process assessing (Fig. 6).

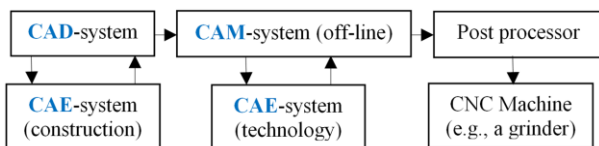

Fig. 6. Integrated system CAD/CAM/CAE in mechanical engineering technology

Source: compiled by the author

At the CAD stage of the product life cycle the product design is performed with computer packages (Compass, Solid works, AutoCAD, Inventor, etc.). According to Fig. 6 optimization of the product constructive parameters is carried out using the constructive systematic engineering calculations (ANSIS, MATLAB, etc.) of CAE-system (construction).

At the CAM stage of the product life cycle, process design is performed with special computer packages (COMPASS Auto-project, Vertical, Mastercam, T-flex, etc.). According to Fig. 6 optimization of the process parameters is carried out

using the constructive systematic engineering calculations (COMSOL Multiphysics, MathCAD, MATLAB, etc.) of CAE-system (technology). It makes it possible to justify the adopted technology from the product quality assurance point of view, for example, the thermal fields and thermal stresses calculations in grinding to predict grinding burns and microcracks, etc.

At the post-processor stage (Fig. 6) a control program for CNC machine is prepared to control the machine at the production stage. This is the stage of actual implementation of work, for the sake of which all the previous stages of the product life cycle have been completed.

In accordance with the general systems theory methodology, the structure and parameters of the developed technological system are found based on the goal that must be achieved during the development and operation of this system. For multi-stage technological design processes at each of the intermediate design stages, there is an intermediate goal, the achievement of which is the task of these intermediate stages. Thus, a multi-stage design procedure corresponds to a “tree of goals”, the top of which is the ultimate (final) goal facing the developer of the technological system.

The task of formalizing the design procedure lies in the multi-stage linking of intermediate goals and intermediate decisions made in such a way as to ensure the achievement of the ultimate (final) goal. In this sense, the design process is an object of control. The project developer (human or computer) is the governing body (regulator), and the developer's ultimate goal is to create a project in the form of a certain information model (Fig. 7).

The decisions making by a developer are essentially control (regulatory) actions leading to a change in the structure and parameters of the designing technical system-process or technical system-construction.

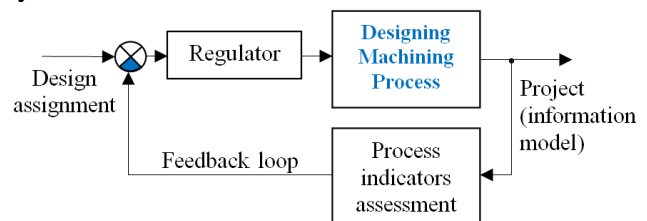

Fig.7. Computer-aided design process control system (pre-production stage)

Source: compiled by the author

At the stage of production preparation (Fig. 7), the controlling (estimating) values are economic indicators (productivity, technological cost, economic profit). The input reference for the design of a technological process as it applied, for example,

to mechanical engineering technology, is a drawing of a part with the corresponding requirements for dimensional accuracy and quality of the surface and surface layer. Further, there is a governing body (regulator) that makes a decision on the development of a technological process. Feedback (feedback loop in Fig. 7) allows you to identify the discrepancy between the requirements of the drawing at the input of the system and the estimated parameters of the part, which can be assumed with the accuracy of the information model of the created object (e.g., a part to be machined). In addition, at the stage of production preparation the information model of the future technological process is assessed according to the above economic indicators.

If, for example, the technological cost of the created object (objective function) does not correspond to the specified value, then the design (creation of the information model) will continue. This relentless action will continue until an acceptable value of the objective function is achieved due to changes in the parameters and structure of the technological process being developed. Thus, with automated technological design, it is possible to optimize the creating technological process.

At the production stage, the input reference entering in a closed loop system with feedback (Fig. 8) is the parameters obtained at the stage of production preparation. At the output of the system (Fig. 8) the actual technological indicators (for example, the parameters of accuracy and quality of the processed part) are recorded.

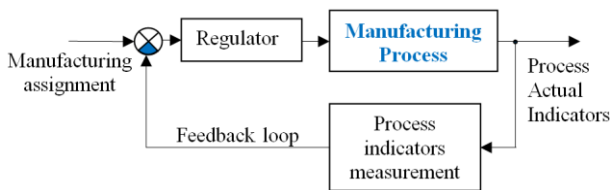

Fig. 8. Process automatic control system (production stage)

Source: compiled by the author

An additional feature of the biomedical implant manufacturing technology is how to obtain information about the required initial (individual for a given patient) shape of these parts at the design stage of the constructive structures of these parts (CAD) and at the design stage of their manufacturing technology (CAM). In the first case (CAD), the geometric description of the required implant part (drawing) is obtained on the basis of the patient's computed tomography data (reconstruction of an unworn joint based on the measurement of a worn

out joint), in the second (CAM) – on the basis of a preliminary measurement of the manufactured billet-casting. The second dimension (measurement of the workpiece) is caused by the imperfection of the method of manufacturing the workpiece, since during the production of this workpiece it is impossible to ensure the required dimensional accuracy and quality of the surface layer that are required according to the drawing of this part. Precision casting methods such as injection molding and centrifugal casting do not meet the requirements of the implant drawing. Measurement of the workpiece is done, for example, by laser scanning or using a Renishaw tactile probe.

Billets for free-form parts with individual (non-repeating) dimensions require additional machining, for example, grinding according to an individual control program. The above second measurement provides information for the individual orientation of the workpiece before grinding, based on the least uneven machining allowance.

The final stage of computer-aided design and manufacturing of complex-profile parts (both machine parts and implants) is the development of subsystems for designing, monitoring and diagnosing of the grinding operation in accordance with the diagram in Fig. 9.

The grinding temperature is determined, for example, through the specific work of grinding, by solving the Fourier thermal conductivity equation under boundary conditions of the second kind.

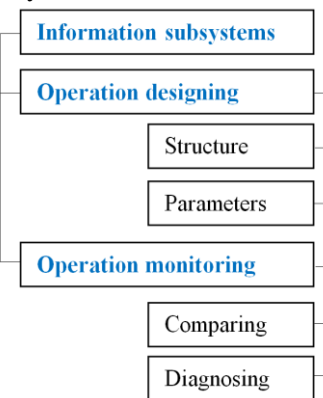

Fig. 9. Information subsystems for complex-shaped parts including biomedical implants

Source: compiled by the author

The equation of thermal conductivity in the COMSOL Multiphysics window looks like

$$\rho C_p \frac{\partial T}{\partial t} + \rho C_p \mathbf{u} \cdot \nabla T + \nabla \cdot \mathbf{q} = Q,$$

where: ρ is the material density, kg/m^3 ; C_p is the specific heat capacity; $\text{J}/(\text{kg} \cdot ^\circ\text{C})$, \mathbf{u} is the velocity vector, m/s ; ∇T is the temperature gradient, $^\circ\text{C/m}$;

\mathbf{q} is the heat flux vector, W/m^2 ; Q is the heat source power per unit volume, W/m^3 .

The velocity vector can be written as

$$\mathbf{u} = u_x \mathbf{i} + u_y \mathbf{j} + u_z \mathbf{k},$$

where: u_x, u_y, u_z are components of the velocity vector in the thermal conductivity medium, m/s ; $\mathbf{i}, \mathbf{j}, \mathbf{k}$ are single vectors or ords in the Cartesian coordinate system.

The temperature gradient $\overline{\nabla T} = \overline{\text{grad} T}$ is a vector that is directed normal to an isothermal surface in the direction of temperature increase and is numerically equal to a temperature change per unit length, i.e.

$$\overline{\text{grad} T} = \mathbf{n} \frac{\partial T}{\partial n} \text{ or } \overline{\nabla T} = \mathbf{n} \frac{\partial T}{\partial n},$$

where: \mathbf{n} is the normal unit vector; $\overline{\nabla}$ is the vector differential operator, i.e. a symbolic vector that replaces the gradient symbol T .

In the Cartesian coordinate system, the $\overline{\nabla T}$ gradient vector of the function T denoted by as the following vector

$$\overline{\nabla T} = \frac{\partial T}{\partial x} \cdot \mathbf{i} + \frac{\partial T}{\partial y} \cdot \mathbf{j} + \frac{\partial T}{\partial z} \cdot \mathbf{k}.$$

Since $\mathbf{n} = \mathbf{i} + \mathbf{j} + \mathbf{k}$, then

$$\frac{\partial T}{\partial n} = \frac{\partial T}{\partial x} \cdot \mathbf{i} + \frac{\partial T}{\partial y} \cdot \mathbf{j} + \frac{\partial T}{\partial z} \cdot \mathbf{k}.$$

The scalar product of two vectors \mathbf{u} and $\overline{\nabla T}$ can be written as

$$\mathbf{u} \cdot \overline{\nabla T} = u_x \frac{\partial T}{\partial x} + u_y \frac{\partial T}{\partial y} + u_z \frac{\partial T}{\partial z},$$

where u_x, u_y, u_z are the \mathbf{u} vector projections on the corresponding coordinate axes x, y, z .

The vector of the heat flux

$$\mathbf{q} = -\lambda \cdot \overline{\nabla T}.$$

The scalar product of two vectors $\overline{\nabla}$ and \mathbf{q}

$$\overline{\nabla} \cdot \mathbf{q} = -\lambda \left(\frac{\partial^2 T}{\partial x^2} + \frac{\partial^2 T}{\partial y^2} + \frac{\partial^2 T}{\partial z^2} \right).$$

The vector-scalar transformations carried out above explain the close agreement between analytical model and FEM simulation. The more elementary is the geometric shape of the profile being ground the closer will be the results of determining the temperature during analytical modeling and FEM simulation. In other words, during the FEM simulation at each point of the profile, the usual analytical model operates and the FEM simulation takes into account the “interaction” (mutual influence) of these “instantaneous”

analytical models, i.e. takes into account the vector nature of heat fluxes and temperature gradient. When FEM simulating, any value of the heat flux can be set (and this will be taken into account) at each point on the surface, while in the analytical model the heat flux is either constant or equal to some average value.

Thus, the use of the vector form for describing the temperature field in COMSOL Multiphysics program allows us to solve the problem of determining the temperature taking into account the influence of the geometric shape of the surface being ground.

3. RESULTS

The general approach to the development of automated grinding technology for complex-profile parts is shown below for profile grinding on a Höfler Rapid 1250 CNC machine. The grinding stock allowance parameters, characterize the grinding operation performance, namely the specific material removal rate Q'_w , and material removal rate V'_w through the grinding temperature studied above.

The grinding stock allowance in contrast to that for flat surface and round grinding is an ambiguous characteristic of the thickness of the layer to be cut, due to the complex shape of the profile of the gear gap and its offset on the periphery of the gear. This leads to the dependence of the allowance on its location on the profile, on the direction of its measurement relative to the surface (perpendicular, vertical or horizontal in the coordinate system of the gear gap) and on the location of the gap on the periphery of the gear.

When developing the technological process of manufacturing gears for each operation there is a normative (nominal) allowance provided by the technologist, in accordance with the technological process, including for tooth-forming operations: milling and grinding. The layer of metal removed during gear milling contains an overlap (extra material but not stock allowance) and a stock allowance (removed, respectively, by roughing and finishing mills).

The stock allowance remaining for grinding is equidistantly positioned relative to the finished profile according to the drawing, i.e., is kept constant in the direction normal to the tooth profile. Equidistant stock allowance on parts of complex shape allows in the next heat treatment to provide a uniform layer of hardened material at any point of the complex profile.

In this regard, there are two strategies to remove the grinding stock allowance: equidistant infeed and radial infeed of grinding wheel. In

practice, the strategy of radial infeed of grinding wheel is more widely used, based on the principle of operation “by the method of copying” due to simple movements of the machine.

The method of initial orientation of the workpiece before grinding is to align the minimum values of the stock allowances on the left and right sides of the gear gaps [34]. For this, one of the gaps of the gear, moreover random (hereinafter the initial one), is placed in the measurement zone, and the gear wheel is preliminarily fixed on the faceplate. Then the gear wheel is aligned, i.e., the radial runout value is identified with controlled accuracy along the base surface of the gear wheel with an unlocked indexing disc. After that, the dividing disc is fixed, the measuring tips are inserted into the gap in the measurement zone, and by turning the faceplate relative to the dividing disc using the faceplate turning mechanism, and the allowance is leveled on both sides of this initial gap of the gear wheel. The setting of the reading device of the measuring units to the zero position is carried out according to the reference product, ground to the lower limit size of the tooth thickness. After measuring all the gaps on the recording device (printer), a combined diagram of the stock allowance distribution on the left and right sides of the controlled gear gap will be drawn (Fig. 10,a).

The curves of the stock allowance distribution on the left and right sides of the teeth (Fig. 10,a) are labeled by “Left” and “Right”, respectively. From this diagram (Fig. 10,a) it can be seen that the value of the smallest stock allowance for grinding is a negative value $z_{\min}^L < 0$ (sector of the gap E). This means that for a given angular position of the gear wheel on the machine in the sector of the gap E , there will be “rough spots” on the left sides of the gaps, i.e., after finishing machining the grinding wheel will not touch these sides of the gaps.

According to the allowance diagram (Fig. 10, a), the difference of the minimum stock allowances on the left and right sides of the gaps $N = z_{\min}^L - z_{\min}^R$ is determined (the left side of the tooth is the right side of the gap and vice versa) and unfold the faceplate with the controlled wheel relative to the dividing disc in the direction of the side with the largest minimum stock allowance of the minimum ones. In the case under consideration, $N = 0.09$ mm. The reversal (correction) value is equal to the half difference of the minimum allowances, i.e. $N/2 = 0.045$ mm. The turn value of 0.045 mm is recorded visually using the reading device of the measuring unit or automatically using a digital encoder (angle sensor).

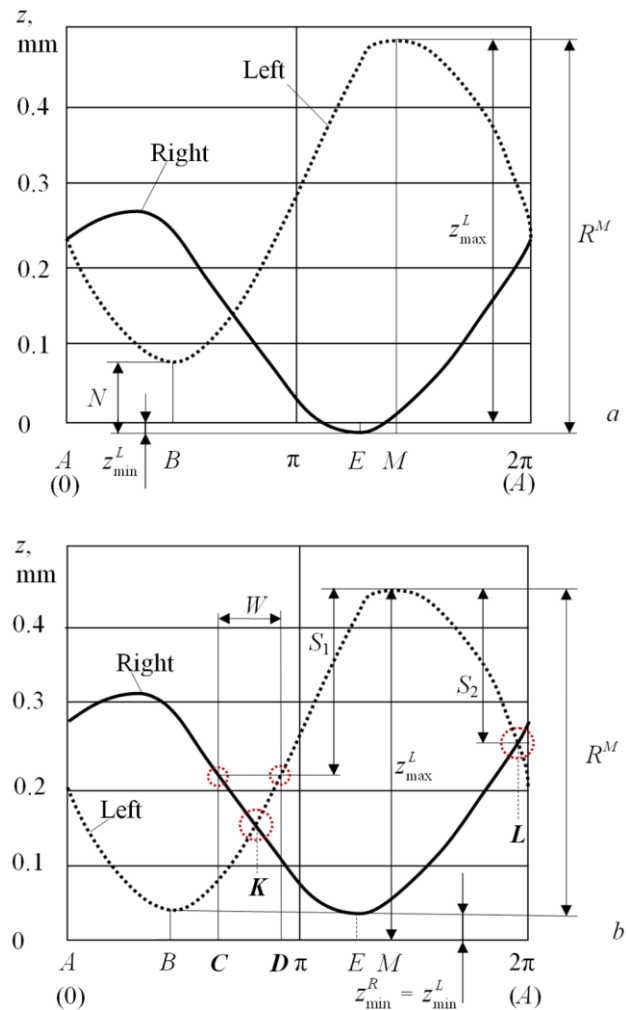

Fig. 10. The stock allowance distribution on the left (Left) and right (Right) sides of the teeth before (a) and after (b) making a correction to the angular position of the gear

Source: compiled by the author

After correcting the angular position of the controlled gear, the allowance is remeasured and recorded on both sides of its teeth, and a new combined stock allowance distribution diagram is constructed (Fig. 10,b). In this diagram, the minimum stock allowance will be aligned and equal to the smallest stock, i.e., $z_{\min}^R = z_{\min}^L$ (gaps B and E in Fig. 10).

According to the new stock allowance diagram, adjusting gaps are determined, having simultaneously ground opposite sides of the teeth with the same grinding stock allowance. Here it is necessary to take into account the scheme of shaped gear grinding according to the copying method: grinding with two shaped wheels or grinding with one shaped wheel. When grinding with two different shaped wheels, the angular distance W is known. Knowing this distance, we find the adjustment gaps

C and D (Fig. 10b), which are located at an angular distance W . Simultaneously processed sides (with the same stock allowance on each side) of different adjustment gaps are marked on the gear, i.e. the markup is made.

When grinding with one shaped wheel, the left and right profiles of which are in the same gap of the gear wheel ($W = 0$), the adjustment gaps are in sectors K and L (Fig. 10b). Of these two sectors, it is necessary to choose the one in which the adjustment gap is located closer to the intersection of the continuous curves “Left” and “Right”, for example, sector L is selected from two sectors K and L .

If in the stock allowance diagram there are no simultaneously ground tooth gaps with the same allowance (it is caused by the discrete arrangement of the gaps, in contrast to the continuous trend of the stock allowance distribution), then the gaps that have simultaneously ground opposite sides of the teeth with the smallest difference in the stock allowance are selected as adjustment ones.

After selecting the adjustment gaps, the difference S is determined between the largest stock

allowance along the entire gear wheel in the gap and the stock allowance of the opposite sides of the teeth with an equal stock allowance of the adjustment gaps. The S value is equal to or proportional to the retraction of the grinding wheel after orientation along it on the machine tool of opposite sides of the teeth with the same stock allowance for the adjustment gaps. Retraction of the grinding wheel by the value S from the sides of the teeth of the adjustment gaps prevents an increase in the depth of cut in the first pass in the sectors of the gear crown with the greatest stock allowance.

For the two considered cases of the choice of adjustment gaps, i.e., grinding with two shaped wheels or one shaped wheel, the corresponding values of the indicated parameter are $S1$ and $S2$ (Fig. 10b). The result of the implementation of the described method on a gear with 40 teeth on a Höfler Rapid 1250 machine is shown in Fig. 11 and corresponds to the described algorithm for aligning the minimum values of the grinding stock allowance.

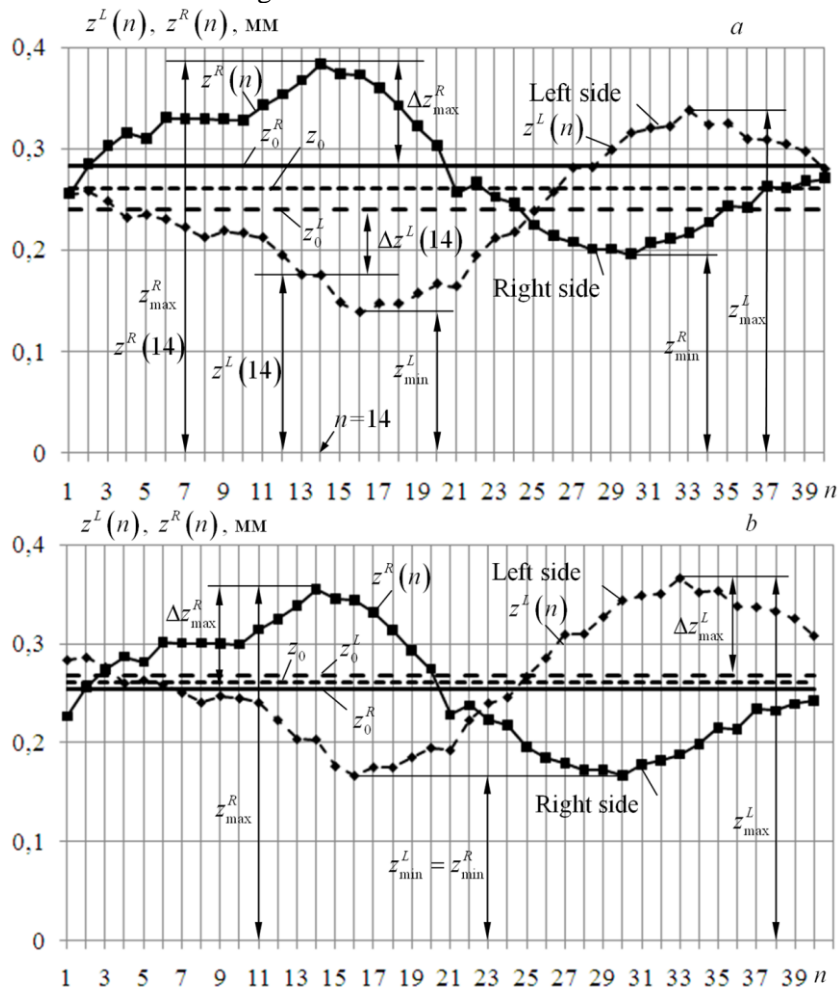

Fig. 11. The distribution of the grinding stock allowance along the tooth cavities of the gear wheel before (a) and after (b) additional rotation of the work piece around its axis

Source: compiled by the author

Thus, the initial orientation of a complex-shaped billet of a gear wheel is a special case of installing and basing a complex-shaped part. The system for measuring the stock allowance for this case is based on touching the tactile sensors of the lateral sides of the gear gaps. After measuring the actual location of the stock allowance, it becomes possible to determine the grinding parameters taking into account the actual grinding temperature [35, 36], [37, 38], [39, 40] and with using intelligent control systems [41, 42], [43, 44], [45, 46], [47].

CONCLUSIONS

1. Based on the analysis of the principle of building an intelligent control system (according to Saridis), it was found that three levels of the hierarchy of an intelligent system correspond to three levels of the hierarchy of control, which (control), being a single one in a hierarchical intelligent system, involves the selection of the corresponding (three) control objects. At the top level of the hierarchy, the subordinate plant services of the enterprise organizational structure are the object of management. Such control is characterized by the term “management” and corresponds to the domestic level of “production organization”. At the middle level of the hierarchy, “adaptive control” takes place, when the structure and parameters of the machining process system are developed based on the potentially available process equipment means and the technological requirements of the suppliers of these means. At the lowest level of the hierarchy of an intelligent system (the level of a CNC machine tool), there is automatic control (open and closed) and, therefore, control is characterized by the terms “regulation”, “stabilization”, “program and/or tracking control”.

2. A new scientific statement on the “quality of a technological operation” has been formulated, under which (quality) it is proposed to understand a set of three criteria: the material removal rate (operation productivity), the quality of the part which have been machined (part quality), the labor intensity and the technological cost of the operation (operation efficiency).

3. Based on the general control theory for systems with negative feedback, a mechanism for making technological decisions at the stages of production preparation and production itself is shown. At the stage of production preparation (pre-production), a project of the future technological process (information model) is created, and at the stage of production itself, the created project is

additionally improved achieving the set goals and taking into account the existing disturbances that cannot be taken into account in the production preparation stage.

4. It is shown that production management is based on a hierarchical (i.e., multilevel) decision-making principle, which follows from the multi-stage design processes and automation of the corresponding technological solutions. At the same time, intermediate goals correspond to intermediate solutions. The “tree of intermediate decisions” corresponds to the “tree of intermediate goals”.

5. The new provisions for the automation of technical systems (processes and constructions) developed in the paper are universal in nature, regardless of the specifics of production processes (mechanical engineering, food industry, medicine and pharmaceuticals, etc.) and can be used in the development of intelligent control systems covering the stages of production and its preparation.

6. The main reasons for designing and implementing industrial automation, e.g., CNC machines, robotized complexes, flexible manufacturing systems and so on are the economic benefits of the systems. They include first of all greater productivity, which means a greater output and a lower unit cost on a smaller floor space. While automation requires fewer machine operators or none at all, the remaining staff (production engineers, computer programmers and maintenance engineers) has to be highly skilled. This requirement can be met by improving the quality of education on automation in higher educational institution with the account of the principles discussed in the paper.

7. A principle of interpenetration of mechanical engineering and biomedical technologies is established in accordance with which the modern technologies of casting (melting), spraying and machining with a grinding wheel make it possible to improve clinical methods of prosthetics in dentistry and implantology, leaving them accessible to everyone, while improving the quality, and as a result, the products service life.

8. The carried out vector-scalar transformations explain the close agreement between analytical model and FEM simulation in determining the grinding temperature. The more elementary is the geometric shape of the profile being ground the closer will be the results of determining the temperature during analytical modeling and FEM simulation. In other words, during the FEM simulation at each point of the profile, the usual analytical model operates and the FEM simulation

takes into account the “interaction” (mutual influence) of these “instantaneous” analytical models, i.e. takes into account the vector nature of heat fluxes and temperature gradient. When FEM simulating, any value of the heat flux can be set (and this will be taken into account) at each point on the surface, while in the analytical model the heat flux is either constant or equal to some average value.

ACKNOWLEDGMENTS

This work was carried out in accordance with the state (Ukraine) budget theme of the Odessa National Polytechnic University (2018 – 2021, registration code: 0118U004400).

REFERENCES

1. Krainev, A. F. “Mechanism Reference Dictionary”, 2nd edition revised and enlarged. *Mechanical engineering* (in Russian). Moscow: Russian Federation. 1987. 560 p.
2. Brazel, E. “Power and Position-Oriented Process Monitoring of Freeform Abrasive Machining”. A thesis submitted to the University of Dublin in partial fulfillment of the requirements for the degree of Doctor in Philosophy. 2013. 206 p.
3. Petrakov, Y. & Shuplietsov, D. “Programming of Adaptive Machining for End Milling”. *Mechanics and Advanced Technologies*. 2017; 1(79): 34–40.
4. Brazel, E., Hanley, R., Cullinane, R. et al. Position-oriented Process Monitoring in Freeform Abrasive Machining. *Int J Adv Manuf Technol* 69. 2013. p.1443–1450. DOI: <https://doi.org/10.1007/s00170-013-5111-x>.
5. Ramsden, J. J., Allen, D. M., Stephenson, D. J., Alcock, J. R., Peggs, G. N., Fuller, G. & Goch, G. “The Design and Manufacture of Biomedical Surfaces”. *CIRP Ann Manuf Technol*. 2007; 56(2): 687–711.
6. Tönshoff, H. K., Friemuth, T. & Becker. J. C. “Process monitoring in grinding”. *CIRP Ann Manuf Technol*. 2002; 51(2): 551–571.
7. Klocke, F., Kratz, S., Auerbach, T., Gierlings, S., Wirtz, G. & Veselovac, D. “Process Monitoring and Control of Machining Operations”. *Int J Autom Technol*. 2011; 5(3): 403–411.
8. Teti, R., Jemielniak, K., O'Donnell, G. & Dornfeld, D. “Advanced Monitoring of Machining Operations”. *CIRP Ann Manuf Technol*. 2010; 59(2): 717–739.
9. Jemielniak, K. “Commercial Tool Condition Monitoring Systems”. *Int J Adv Manuf Technol*. 1999; 15(10): 711–721.
10. Lima, P. U. & Saridis, G. N. “Design of Intelligent Control Systems Based on Hierarchical Stochastic Automata”. *World Scientific Publishing Co. Pte. Ltd.* Singapore. 1996. 155p.
11. Kyratsis, P., Kakoulis, K. & Markopoulos, A. P.: “Advances in CAD/CAM/CAE”. *Technologies/Machines*. 2020; 8: 13. DOI: <https://doi.org/10.3390/machines8010013>.
12. Wang, L. & Chen, Z. C. “A New CAD/CAM/CAE Integration Approach to Predicting Tool Deflection of End Mills”. *Int J Adv Manuf Technol*. 2014; 72: 1677–1686.
13. Wang, L. M. “A New CAD/CAM/CAE Integration Approach to Modelling Flutes of Solid End-Mills”. *A thesis in the department of mechanical and industrial engineering*. Montreal Quebec. Canada. 2014; 147 p.
14. Wagner, E. “A New Optimization CAD/CAM/CAE Techniques for the Processing of the Complex 3D Surfaces on 5 Axes CNC Machines”. *Procedia Technology*. 2015; 19:34–39.
15. Wang, J., Niu, W., Ma, Y. et al. “A CAD/CAE-integrated Structural Design Framework for Machine Tools”. *Int J Adv Manuf Technol*. 2017; 91: 545–568.
16. Kountanya, R., Guo, C. “Specific Material Removal Rate Calculation in Five-axis Grinding”. *Journal of Manufacturing Science and Engineering-transactions of the ASME*. 2017;139: 121010-1 – 121010-6.
17. Jin, T., Yi, J. Li, P. “Temperature Distributions in Form Grinding of Involute Gears”. *Int J Adv Manuf Technol*. 2017; 88: 2609–2620.
18. Malkin, S., Guo, C. “Thermal Analysis of Grinding”. *CIRP Annals Manufacturing Technology*. 2007; 56 (2): 760–782.
19. Lishchenko, N., Larshin, V. “Profile Gear Grinding Temperature Determination”. *In: 4th International Conference on Industrial Engineering. ICIE, Lecture Notes in Mechanical Engineering. Publ. Springer*, 2019. p.1723–1730. DOI: <https://doi.org/10.30929/1995-0519.2018.1.100–108>.

20. “A Systematic Method for Grinding Wheel Performance Evaluation”. – Available at: <https://www.semanticscholar.org/paper/A-Systematic-Method-for-Grinding-Wheel-Performance-Mcspadden-Hughes/3721ff16ac64dbc08fb75e0911bc2542ea3d1da2>. – [Accessed: 21th June 2020].
21. Weinert, K., Blum, H., Jansen, T. et al. „Simulation Based Optimization of the NC-shape Grinding Process with Toroid Grinding Wheels”. *Prod. Eng. Res. Devol.* 2007; 1: 245–252.
22. Berend Denkena, Luis de Leon & Leif Behrens. “Contact Conditions in 5-axis-grinding of Double Curved Surfaces with Toric Grinding Wheels”. *Advanced Materials Research*. 2010; Vol. 126-128: 41–46. DOI: <https://doi.org/10.4028/www.scientific.net/AMR.126-128.41>.
23. Heinzl, C., Sölter, J., Jermolajev, S., Kolkwitz, B. & Brinksmeier, E. “A Versatile Method to Determine Thermal Limits in Grinding”. *2nd CIRP Conference on Surface Integrity (CSI) Procedia CIRP 13*. 2014. p.131–136.
24. Patil Prashant & Patil Chandrakant. “FEM Simulation and Analysis of Temperature Field of Environmental Friendly MQL Grinding”. Proceedings of the international conference on communication and signal processing 2016 (ICCASP/ICMMD-2016). *Published by Atlantis Press*. 2017. p.182–186.
25. Jun, Yi, Wei, Zhou & Zhaohui, Deng. “Experimental Study and Numerical Simulation of the Intermittent Feed High-Speed Grinding of TC4 Titanium Alloy Metals”. *Metals*. 2019; 9(7): 802. DOI: <https://doi.org/10.3390/met9070802>.
26. Lan, S. & Jiao, F. “Modeling of Heat Source in Grinding Zone and Numerical Simulation for Grinding Temperature Field”. *Int J Adv Manuf Technol*. 2019; 103: 3077–3086.
27. “Technologies – Balancing, Acoustic & Vibration Sensors”. – Available at: <https://www.marposs.com/eng/application/technologies-balancing-acoustic-vibration-sensors>. – [Accessed: 21th June 2020].
28. Koenig, W., Altintas, Y. & Memis, F. “Direct Adaptive Control of plunge Grinding Process Using Acoustic Emission (AE) Sensor”. *International Journal of Machine Tools and Manufacture*. 1995; Vol. 35: 1445–1457.
29. Alexandre, F. A., Lopes, W. N. & Lofrano Dotto, F. R. et al. “Tool Condition Monitoring of Aluminum Oxide Grinding Wheel Using AE and Fuzzy Model”. *Int J Adv Manuf Technol*. 2018; 96: 67–79.
30. Chien-Sheng Liu & Yang-Jiun Ou. “Grinding Wheel Loading Evaluation by Using Acoustic Emission Signals and Digital Image Processing”. *Sensors*. 2020; 20, 4092. DOI: <https://doi.org/10.3390/s20154092>.
31. Zheng Zhao, Chenggang Hou & Shengnan Duan. “Online Intelligent Monitoring System of Grinding Process Based on Process Modeling”. *Second International Conference on Instrumentation & Measurement, Computer, Communication and Control*. 2012. p.327–330.
32. Tian, Y. B., Liub, F., Wang, Y. & Wu, H. “Development of Portable Power Monitoring System and Grinding Analytical Tool”. *Journal of Manufacturing Processes*. 2017; Vol. 27: 188–197.
33. Amelia Nápoles Alberro, Hernán A. González Rojas, Antonio J. Sánchez Egea, Saqib Hameed & Reyna M. Peña Aguilar. “Model Based on an Effective Material-Removal Rate to Evaluate Specific Energy Consumption in Grinding”. *Materials*. 2019; 12. 939. DOI: <https://doi.org/10.3390/ma12060939>.
34. Larshin, V. & Lishchenko N. “Adaptive Profile Gear Grinding Boosts Productivity of this Operation on the CNC Machine Tools”. In: Ivanov V. et al. (eds.). *Advances in Design, Simulation and Manufacturing. DSMIE 2018. Lecture Notes in Mechanical Engineering. Publ. Springer*. Cham: Germany. 2019.
35. Lishchenko, N. & Larshin, V. “Grinding Temperature Model Simplification for the Operation Information Support System”. *Scientific Journal Herald of Advanced Information Technology. Publ. Nauka i Tekhnika*. Odessa: Ukraine. 2019; Vol. 2 No.3:197–205. DOI: <https://doi.org/10.15276/hait.03.2019.3>.
36. Lishchenko, N. & Larshin, V. “Temperature Models for Grinding System State Monitoring”. *Applied Aspects of Information Technology. Publ. Science and Technical*. Odessa: Ukraine. 2019; Vol.2 No.3: 216–229. DOI: <https://doi.org/10.15276/aait.03.2019.4>.
37. Lishchenko, N. & Larshin, V. “Comparison of Measured Surface Layer Quality Parameters with Simulated Results”. *Applied Aspects of Information Technology. Publ. Nauka i Tekhnika*. Odessa: Ukraine. 2019; Vol. 2 No.4: 304–316. DOI: <https://doi.org/10.15276/aait.02.2019.5>.
38. Carslaw, H. S. & Jaeger, J. C. “Conduction of Heat in Solids”. *Oxford University Press*. Oxford. 1959. 510 p.
39. Lishchenko, N. & Larshin. V. “Temperature Field Analysis in Grinding”. *Lecture Notes in Mechanical Engineering. Publ. Springer*. 2020. p.199–208. DOI: https://doi.org/10.1007/978-3-030-22365-6_20.

40. Lishchenko, N. & Larshin, V. “Gear-Grinding Temperature Modeling and Simulation”. *Lecture Notes in Mechanical Engineering*. Publ. Springer. 2020. p. 289–297. DOI: https://doi.org/10.1007/978-3-030-22063-1_32.
41. Oleksandr V. Komarov. “Reducing the Search Area of Genetic Algorithm Using Neural Network Autoencoder”. *Scientific Journal Herald of Advanced Information Technology*. Publ. Nauka i Tekhnika. Odessa: Ukraine. 2020; Vol.3 No.3: 113–124. DOI: <https://doi.org/10.15276/hait.03.2020.1>.
42. Anastasiia P. Dydyk, Olena K. Nosovets, Vitalii O. Babenko. “Setting up the Genetic Algorithm for the Individualized Treatment Strategy Searching”. *Scientific Journal Herald of Advanced Information Technology*. Publ. Nauka i Tekhnika. Odesa: Ukraine. 2020; Vol.3 No.3: 125–135. DOI: <https://doi.org/10.15276/hait.03.2020.2>.
43. Galina Yu. Shcherbakova, Viktor N. Krylov, Olha E. Plachinda. “Determination of Characteristic Points of Electrocardiograms Using Multi-Start Optimization with a Wavelet Transform”. *Scientific Journal. Herald of Advanced Information Technology*. Publ. Nauka i Tekhnika. Odessa: Ukraine. 2020; Vol.3 No.2: 23–33. DOI: <https://doi.org/10.15276/hait.02.2020.2>.
44. Yuriy V. Khoma, Mirosław Szmajda & Mariusz Pelc. “Development of Scientific-Methodological Approaches of Machine Learning Application in Biosignals Processing”. *Scientific Journal. Herald of Advanced Information Technology*. Publ. Nauka i Tekhnika. Odessa: Ukraine. 2020; Vol.3 No.1: 383–394. DOI: <https://doi.org/10.15276/hait.01.2020.5>.
45. Denis S. Shibaev, Vladimir V. Vychuzhanin, Nikolay M. Rudnichenko, Natalia O. Shibaeva & Tatyana V. Otradskaia. “Data Control in the Diagnostics and Forecasting the State of Complex Technical Systems”. *Scientific Journal. Herald of Advanced Information Technology*. Publ. Nauka i Tekhnika. Odessa: Ukraine. 2019; Vol.2 No.3: 183–196. DOI: <https://doi.org/10.15276/hait.03.2019.2>.
46. Vasily P. Larshin, Natalia V. Lishchenko & Jan Pitel. “Intermittent Grinding Temperature Modeling for Grinding System State Monitoring”. *Applied Aspects of Information Technology*. Publ. Science i Technical. Odessa: Ukraine. 2020; Vol.3 No.2: 58–73. DOI: <https://doi.org/10.15276/aait.02.2020.4>.
47. Olexandr N. Romanyuk, Sergey I. Vyatkin, Svetlana G. Antoshchuk, Pavlo I. Mykhaylov & Roman Yu. Chekhmestruk. “Blending Functionally Defined Surfaces”. *Applied Aspects of Information Technology*. Publ. Science i Technical. Odessa: Ukraine. 2019; Vol.2 No.4: 271–282. DOI: <https://doi.org/10.15276/aait.04.2019.2>.

Conflicts of Interest: the authors declare no conflict of interest

Received 06.10.2020

Received after revision 15.11.2020

Accepted 20.11.2020

DOI: <https://doi.org/10.15276/aait.04.2020.3>

УДК 004.942:621.923

ІНФОРМАЦІЙНЕ ЗАБЕЗПЕЧЕННЯ ТЕХНОЛОГІЇ ШЛІФУВАННЯ СКЛАДНОПРОФІЛЬНИХ ДЕТАЛЕЙ

Василь Петрович Ларшин¹⁾

ORCID: <https://orcid.org/0000-0001-7536-3859>, vasilylarshin@gmail.com

Наталія Володимирівна Ліщенко²⁾

ORCID: <https://orcid.org/0000-0002-4110-1321>, odeslnv@gmail.com

- ¹⁾ Одеський національний політехнічний університет, пр. Шевченка, 1, Одеса, 65044, Україна
²⁾ Одеська національна академія харчових технологій, вул. Канатна, 112, Одеса, 65039, Україна

АНОТАЦІЯ

Розроблено методику автоматизованого проектування і виготовлення складно-профільних деталей машин і імплантатів з важкооброблюваних матеріалів (титан, кобальто-хромові сплави, діоксид цирконію та інші), яка заснована на принципах побудови інтегрованої CAD/CAM /CAE системи автоматизованого конструкторського і технологічного проектування та ієрархічної інтелектуальної системи управління. Показано, що кінематичні механізми, які створені протягом декількох останніх століть, не дозволяють відтворювати з необхідною точністю рух суглобів живих організмів для застосування їх в біомедичних технологіях імплантації. Тому, зношені суглоби живих організмів реконструюють, додаючи в них складно-профільні деталі із зазначених важкооброблюваних матеріалів. Інформацію про геометричні форми цих деталей (3D модель) на етапі підготовки виробництва отримують за допомогою сучасних методів комп'ютерної та магнітно-резонансної томографії, а на етапі виробництва фактичне розташування припуску на шліфування визначають лазерним (або

тактильним) скануванням. Для зменшення нерівномірності розташування припуску заготовку складно-профільних деталей перед обробкою орієнтують в системі координат верстата з ЧПК виходячи з встановленого критерію мінімізації припуску. Наводиться приклад такого орієнтування заготовки для деталі типу «колесо зубчасте». Цю заготовку перед зубошлифуванням вимірюють тактильним датчиком Renishaw по лівій і правій сторонах западин зубчастого колеса. Визначають мінімальний припуск по лівій і правій сторонах западин, знаходять різницю між ними, і додатково повертають заготовку зубчастого колеса у відповідному напрямку для вирівнювання цих мінімальних значень припуску. Вирівняні мінімальні припуски, в свою чергу, повинні бути достатні для компенсації впливу технологічних факторів від попередньої операції і похибки установки заготовки для даної операції. Для складно-профільних деталей імплантатів, таку додаткову орієнтацію виробляють, наприклад, по алгоритмам забезпечення мінімаксного значення припуску.

Ключові слова: шліфування; імплантати; проектування; моніторинг; діагностика; шліфувальний круг

DOI: <https://doi.org/10.15276/aait.04.2020.3>

УДК 004.942:621.923

ИНФОРМАЦИОННОЕ ОБЕСПЕЧЕНИЕ ТЕХНОЛОГИИ ШЛИФОВАНИЯ СЛОЖНОПРОФИЛЬНЫХ ДЕТАЛЕЙ

Василий Петрович Ларшин¹⁾

ORCID: <https://orcid.org/0000-0001-7536-3859>, vasilylarshin@gmail.com

Наталья Владимировна Лищенко²⁾

ORCID: <https://orcid.org/0000-0002-4110-1321>, odeslnv@gmail.com

¹⁾ Одесский национальный политехнический университет, пр. Шевченко, 1, Одесса, Украина, 65044

²⁾ Одесская национальная академия пищевых технологий, ул. Канатная, 112, Одесса, Украина, 65039

АННОТАЦИЯ

Разработана методика автоматизированного проектирования и изготовления сложнопрофильных деталей машин и имплантатов из труднообрабатываемых материалов (титан, кобальтохромовые сплавы, диоксид циркония и другие), основанная на принципах построения интегрированной CAD/CAM/CAE системы автоматизированного конструкторского и технологического проектирования и иерархической интеллектуальной системы управления. Показано, что технические механизмы, созданные на протяжении нескольких последних столетий, не позволяют воспроизводить с требуемой точностью движение суставов живых организмов для применения их в биомедицинских технологиях имплантации. Поэтому, изношенные суставы живых организмов реконструируют, добавляя в них сложнопрофильные детали из указанных труднообрабатываемых материалов. Информацию о геометрической форме этих деталей (3D модель) на этапе подготовки производства получают при помощи современных методов компьютерной и магниторезонансной томографии, а на этапе производства (фактическое расположение припуска на шлифование) – лазерным (или тактильным) сканированием. Для уменьшения неравномерности расположения припуска заготовку сложнопрофильной детали перед обработкой ориентируют в системе координат станка с ЧПУ исходя из установленного критерия минимизации припуска. Приводится пример такого ориентирования заготовки для детали типа «колесо зубчатое». Эту заготовку перед зубошлифованием измеряют тактильным датчиком Renishaw по левой и правой сторонам западин зубчатого колеса. Определяют минимальный припуск по левой и правой сторонам западин, находят разность между ними, и дополнительно поворачивают заготовку зубчатого колеса в соответствующем направлении для выравнивания этих минимальных значений. Выравненные минимальные припуски, в свою очередь, должны быть достаточны для компенсации влияния технологических факторов от предыдущей операции и погрешности установки заготовки для данной операции. Для сложнопрофильных деталей имплантатов, такую дополнительную ориентацию производят, например, по алгоритмам обеспечения минимаксного значения припуска

Ключевые слова: шлифование; имплантаты; проектирование; мониторинг; диагностика; шлифовальный круг

ABOUT THE AUTHORS



Vasily Petrovich Larshin – Academician of the Ukrainian Academy of Economic Cybernetics (2020), Dr. Sci. (Eng) (1995), PhD (Eng) (1980), Professor of Department of Mechanical Engineering Technology, Odessa National Polytechnic University, 1, Shevchenko Ave. Odesa, 65044, Ukraine
ORCID: <https://orcid.org/0000-0001-7536-3859>, vasilylarshin@gmail.com

Research field: Production and Technological Processes Information Ensuring

Василь Петрович Ларшин – академік Української академії економічної кібернетики (2020), доктор технічних наук (1995), кандидат технічних наук (1980), професор кафедри Технології машинобудування. Одеський національний політехнічний університет, пр. Шевченка, 1. Одеса, 65044, Україна



Natalia V. Lishchenko – Dr. Sci. (Eng) (2018), PhD (Eng) (2006), Professor of Department of Physics and Materials Science, Odessa National Academy of Food Technologies, 112, Kanatna St. Odesa, 65039, Ukraine
ORCID: <https://orcid.org/0000-0002-4110-1321>, odeslnv@gmail.com

Research field: Information Support of Technological Processes

Наталья Владимировна Лищенко – доктор технічних наук (2018), кандидат технічних наук (2006), професор кафедри Фізики і матеріалознавства. Одеська національна академія харчових технологій, вул. Канатна, 112. Одеса, 65039, Україна