

DOI: <https://doi.org/10.15276/aait.05.2022.9>

UDC 621.233 + 629.113.65 + 519.87

Control optimization of automatic multistage transmission in city electric bus

Ihor Z. Shchur¹⁾ORCID: <https://orcid.org/0000-0001-7346-1463>; ihor.z.shchur@lpnu.ua. Scopus Author ID: 36348908300Viacheslav O. Kovtun¹⁾ORCID: <https://orcid.org/0000-0003-2970-0994>; viacheslav.kovtun.mnee.2020@lpnu.ua¹⁾ Lviv Polytechnic National University. 12, S. Bandera Str. Lviv, 79013, Ukraine

ABSTRACT

The threatening ecological situation in modern cities overloaded with traffic makes it expedient to replace buses with diesel engines with electric buses. In order to increase the energy efficiency of a drive of electric bus and, thanks to this, to expand its power reserve, the paper investigates the feasibility of using a multistage automatic transmission (AT). For research, the Electron E19101 electric bus was taken and two of its variants were considered – a studied one with a six-speed AT and a basic one with a single-speed transmission. For each of the options, the traction characteristics of the electric drive for different positions of the accelerator pedal were formed. Comparative studies of the operation of both variants of the electric bus were carried out by means of computer simulation. For this, computer models of all subsystems of electric buses, as well as external influences that resist movement and determine the load on the electric drive system, were built using the Energetic Macroscopic Representation method in the Matlab/Simulink environment. The application of the specified method makes it possible to simulate the movement of electric bus during a long-term of the adapted FTP-75 standard urban transport cycle. For the studied variant, the AT control system was developed with the aim of current selection of the optimal value of the gearbox transmission ratio, for which the maximum value of the efficiency of the electric drive system is obtained in specific driving conditions. The research results showed a 3.35 % advantage in energy costs for movement in the applied transport cycle of the electric bus with the multistage transmission over the single-stage one. However, as also shown, this advantage increases to 5.3 % during the buses move in the similar transport cycle at low speeds, which occurs in today's traffic-congested cities. In addition, the use of the AT makes it possible to reduce the rated power of the electric bus motor, increase its maximum traction force, which will ensure the possibility of moving with a full load on a large slope, as well as significantly increase the maximum speed of movement, which is important for suburban transportation.

Keywords: Electric bus; automatic multistage transmission; efficiency; control optimization; energetic macroscopic representation (EMR)

For citation: Shchur I. Z., Kovtun V. O. "Control optimization of automatic multistage transmission in city electric bus." *Applied Aspects of Information Technology*. 2022; Vol. 5 No. 2: 120–135. DOI: <https://doi.org/10.15276/aait.05.2022.9>.

INTRODUCTION

All large vehicles (trucks, buses, etc.) are currently equipped with powerful high-volume internal combustion engines (ICEs). This is due to the fact that diesel ICEs have a higher efficiency and higher torque in the low speed range compared to gasoline ICEs that improves the technical and economic performance of transportation. However, engines of this type when burning fuel emit a large number of ultrafine particles. Deteriorating of operating conditions, untimely and unqualified maintenance only worsen the situation that makes vehicles with diesel engines one of the main sources of harmful emissions. In cities where the environmental problem is most acute, such means are, first, large buses. As a result, a number of countries have already banned the operation of diesel vehicles in cities. Therefore, it is advisable to replace buses, especially in cities, with full electric buses [1].

LITERATURE REVIEW

The main sources of onboard power supply for an electric bus are electrochemical batteries. Pre-known route and load on the electric bus allow you to optimally select the type and calculate the capacity of the battery. Given the large weight of the vehicle with passengers, in order to achieve the required power reserve for daytime operation of the electric bus, the installed energy capacity of the batteries must be high that leads to high battery weight, which in turn reduces the range. In order to reduce the weight and cost of batteries, the charging stations for electric buses are installed in a number of cities and the parking in schedule on the route are provided for this purpose [2].

The simplest configuration of the transmission of a full battery electric bus, as well as other electric vehicles, is the use of a single electric motor, a gear with fixed ratio and a differential [3, 4], [5]. However, this configuration requires a complex and expensive traction drive to operate the motor in a

© Shchur I., Kovtun V., 2022

This is an open access article under the CC BY license (<http://creativecommons.org/licenses/by/4.0/deed.uk>)

wide range of speeds and loads – from zero to maximum. Given the traffic conditions of electric buses in cities, the operation of its electric motor very often goes beyond the zones with high efficiency in the reference frame of the electromagnetic torque – angular velocity. This is particularly in the cases at low and high speeds, as well as at high load of the electric bus and the need for high traction force during acceleration and hill climbing. All this leads to additional energy losses in the traction electric drive and to decrease in the power reserve of the electric bus.

As shown in a number of studies [6-9], the use of automatic transmission (AT) allows reducing the overall energy consumption of a full electric vehicle due to the predominant operation of the electric drive in the area with higher efficiency, and reduces the requirements for the speed control range of the traction motor. An AT with different number of gears was used for such transmission: two-speed [6], three-speed [7], four-speed [8], and six-speed [9]. The conducted simulation studies showed a reduction of energy consumption for traffic in standard transport cycles by 5-12 % for electric vehicles with multistage AT compared to transmissions with a fixed gear ratio for the same vehicles. The use of a multistage AT allows the use of a lower power motor to provide the required traction characteristics and allows you to expand its limits both in the direction of increasing the maximum traction force and in the direction of increasing the maximum speed. The work on electric buses [8, 9], [10, 11] is related to the improvement of mechanisms, control systems and speed of shifting of automatic gearboxes. However, there are almost no studies that assess the influence of multistage AT using on the energy efficiency in electric buses.

To model and study the operation of electric vehicles in different transport cycles of their movement, the specialized software environments are used, such as CRUIS [7], or developed packages for computer modeling using a professional computer program for automated manual transmission [12]. This is due to that licensed software products are not available for most researchers. However, such problems can be solved with the help of a recently developed approach based on the energy laws of processes of different physical nature – Energetic Macroscopic Representation (EMR) [13]. Using the principle of action-reaction, in EMR, a complex system is decomposed into interconnected subsystems with energy characteristics, and the structure of the control system based on the principle of inversion

can be directly derived from the main subsystems using certain rules. Simple energy dependences of processes in subsystems are used for the EMR modeling, namely modeling is performed in the available Matlab/Simulink environment. Therefore, this approach is successfully used for computer simulation of different vehicle systems during long transport cycles [14, 15].

THE PURPOSE OF THE ARTICLE

This work is devoted to the development of an algorithm for online optimization of the selection of the AT gear ratio for a city bus to ensure maximum efficiency of its motor and a comparative assessment of energy efficiency of a bus with traditional single-stage transmission and multistage AT in the urban transport cycle.

MAIN PART.

MATHEMATICAL MODELING OF THE ELECTRIC BUS USING THE EMR METHOD

Onboard power supply model

According to Kirchhoff's second law, one of the simplest mathematical models of a power supply, such as a battery, will be:

$$U_B = E_B - I_B R_B, \quad (1)$$

where U_B is the voltage at the output of the battery; E_B is the EMF of the battery; I_B is the battery current, and R_B is the internal resistance of the battery.

Fig. 1a shows a mathematical model of the power supply built in accordance with (1) in the Simulink environment, and Fig. 1b shows the EMR subsystem in which this mathematical model is implemented.

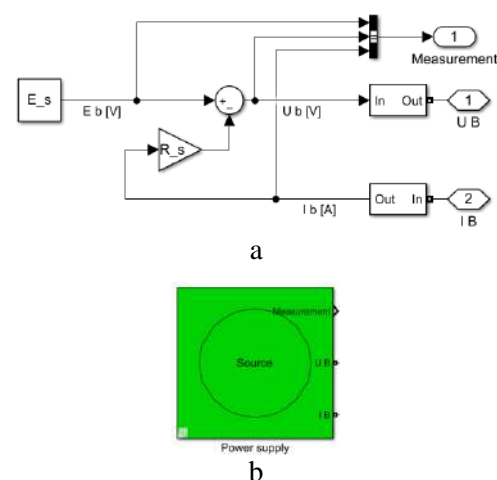

Fig. 1. Simulink model of the power supply (a) and its EMR subsystem (b)

Source: compiled by the authors

The subsystem has one input and one output, the product of which is the power taken by the drive from the source in the traction mode, or given to the source in the regenerative braking mode. The traditional image of subsystems by the EMR method in the Matlab/Simulink environment is taken from [16].

Simplified model of the converter-motor system

A simplified mathematical model that describes the operation of the converter-motor system is based on the following equations.

The mechanical power of the system is calculated as follows:

$$P_M = M_M \omega_M . \tag{2}$$

The power losses in the system:

$$\Delta P = f(M_M, \omega_M) . \tag{3}$$

The electric power consumed by the system is equal

$$P_e = P_M + \Delta P . \tag{4}$$

The motor electromagnetic torque:

$$T_M = T_{M,r} - \tau_M \frac{dT_M}{dt} , \tag{5}$$

where $T_{M,r}$ is the reference of the electromagnetic torque for the control system, and τ_M is the equivalent electromagnetic time constant of the converter-motor system.

The current consumed from the battery by electric drive system is calculated as follows:

$$I_B = \frac{P_e}{U_B} . \tag{6}$$

The Simulink model of the converter–motor system is shown in Fig. 2a, and its EMR subsystem in the form of a multi-physical system is shown in Fig. 2b. The product of current and voltage is the electrical power consumed by the system, and the product of angular velocity and shaft torque is the mechanical power emitted by the system. In the block $P_M + \Delta P$ in tabular form, the dependence (4) is realized.

Multistage transmission model

The mathematical model describing the operation of a gearbox is based on the following equations.

If the gear ratio is

$$i = f(N) , \tag{7}$$

where N is the number of the enabled transmission stage, the torque on the output shaft of the AT is equal

$$T_T = T_M i , \tag{8}$$

and the angular velocity of the motor shaft is calculated as

$$\omega_M = \omega_T i , \tag{9}$$

where ω_T is the angular velocity of the output shaft of the transmission.

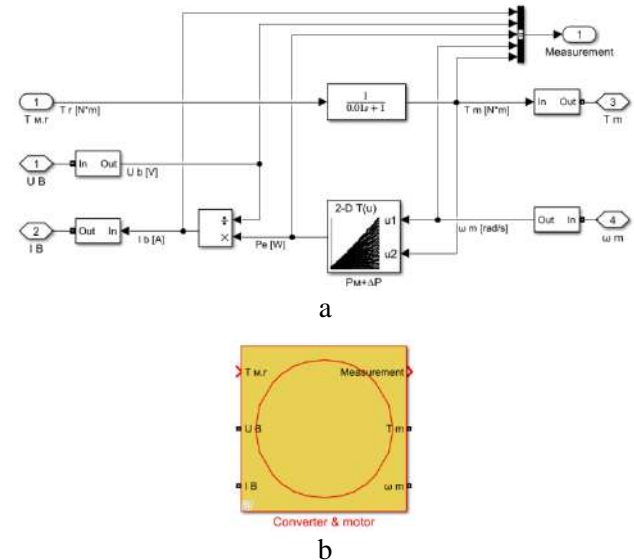

Fig. 2. Simulink model of the converter–motor system (a) and its EMR subsystem (b)

Source: compiled by the authors

The Simulink model of a multistage transmission is given in Fig. 3a, and its EMR subsystem in the form of a mono-physical element is shown in Fig. 3b. The gear ratio is changed using a direct access table $i(N)$, in the rows of which the values of gear ratios are written. The line number corresponds to the serial number of the transmission stage, and the lowest sequence number has the transmission stage with the largest gear ratio and the highest sequence number has the transmission stage with the lowest gear ratio.

Main transmission-wheels system model

The mathematical model of the main transmission (differential) – wheels system is based on the following equations.

Traction force of wheels of the electric bus:

$$F_T = T_T \eta_T \frac{i_g}{r_w} , \tag{10}$$

where η_T is the main transmission efficiency; i_g is the gear ratio of the main transmission (differential), and r_w is the radius of the wheel.

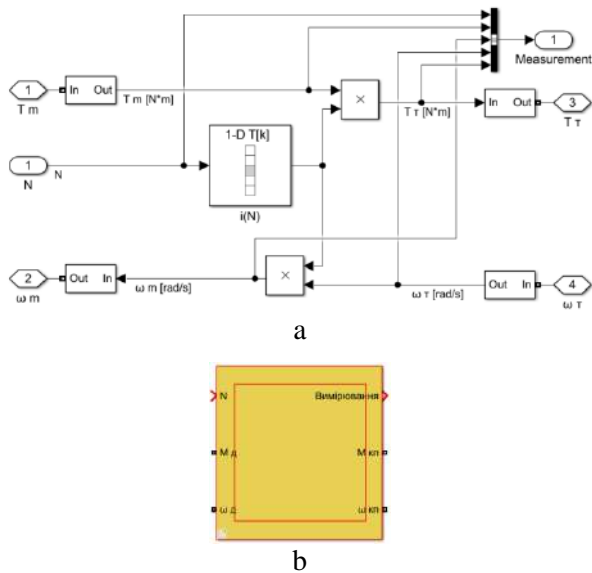

Fig. 3. Simulink model of the multistage transmission (a) and its EMR subsystem (b)
 Source: compiled by the authors

The angular velocity of the input shaft of the main transmission:

$$\omega_T = V_a \frac{i_g}{r_w}, \tag{11}$$

where \$V_a\$ is the electric bus speed.

Simulink model of the main transmission–wheels system is given in Fig. 4a, and its EMR subsystem in the form of a mono-physical element is shown in Fig. 4b. The product of the angular velocity and the torque of the shaft of the transmission is the power of the rotating motion, and the product of the traction force and the speed of the electric bus is the power of the translational motion.

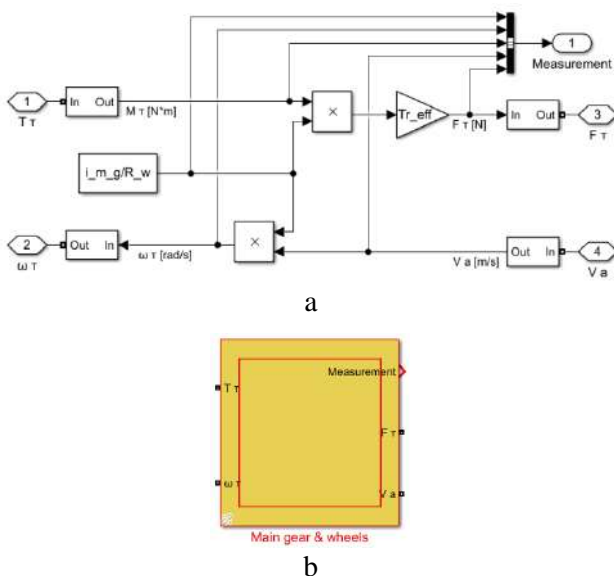

Fig. 4. Simulink model of the main transmission – wheels system (a) and its EMR subsystem (b)
 Source: compiled by the authors

Chassis model

The mathematical model of the chassis is based on the following equations.

The total weight of the electric bus:

$$m_\Sigma = m_e + m_{load}, \tag{12}$$

where \$m_e\$ is the equipped mass of the electric bus, and \$m_{load}\$ is the weight of load.

A differential equation of the dynamics of the electric bus:

$$m_\Sigma \frac{dv_a}{dt} = F_T - F_{ext}, \tag{13}$$

where \$F_{ext}\$ is the external forces acting on the electric bus.

Simulink model of the chassis is given in Fig. 5a, and its EMR subsystem in the form of an element of energy storage is shown Fig. 5b. The inputs of the subsystem are the traction force of the electric bus and the total force of the resistance forces, and the output is the speed of the electric bus.

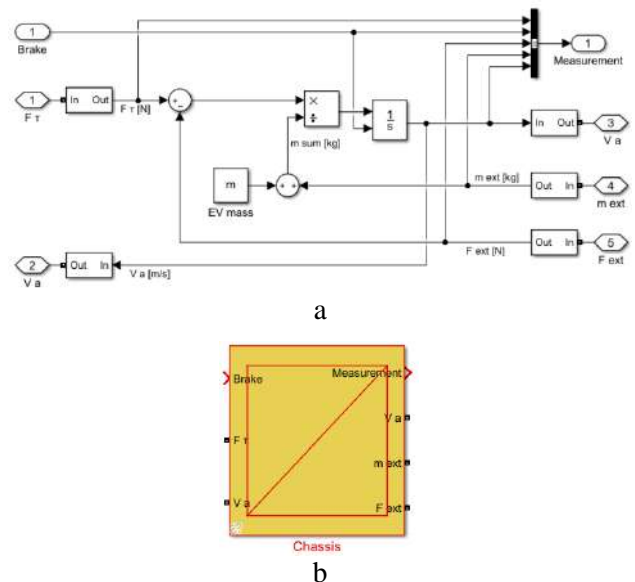

Fig. 5. Simulink model of the bus chassis (a) and its EMR subsystem (b)
 Source: compiled by the authors

Environment model

The mathematical model of an environment, which simulates the forces acting on the electric bus during its movement, is described by the following equations.

Aerodynamic drag force:

$$F_{ad} = 0.5 \rho C_{ad} A_f (V_a + V_{w \rightarrow})^2, \tag{14}$$

where \$\rho\$ is the density of air; \$C_{ad}\$ is the aerodynamic drag coefficient of the body of the electric bus; \$A_f\$ is the front area of the electric bus; \$V_{w \rightarrow}\$ is the projection of the wind speed vector on the direction

of movement of the electric bus (taken with the sign “+” if the wind projection has a direction opposite to the traffic, and with the sign “-” if it agrees with the direction of movement).

If a road angle is

$$\alpha = \text{atan} \frac{h}{100}, \tag{15}$$

where h is the slope of the road in percentage, the rolling resistance is

$$F_{\text{roll}} = m_{\Sigma} g \cos \alpha k_{\text{roll}}, \tag{16}$$

where g is the acceleration of gravity, and k_{roll} is the coefficient of tire rolling resistance, and hill climbing force is

$$F_{\text{hill}} = m_{\Sigma} g \sin \alpha. \tag{17}$$

External force acting on the electric bus:

$$F_{\text{ext}} = F_{\text{ad}} + F_{\text{roll}} + F_{\text{hill}}. \tag{18}$$

Simulink model of the environment is given in Fig. 6a, and its EMR subsystem is shown in Fig. 6b. The input of the subsystem is the speed of the electric bus, and the output is the value of the total driving force and mass of the electric bus.

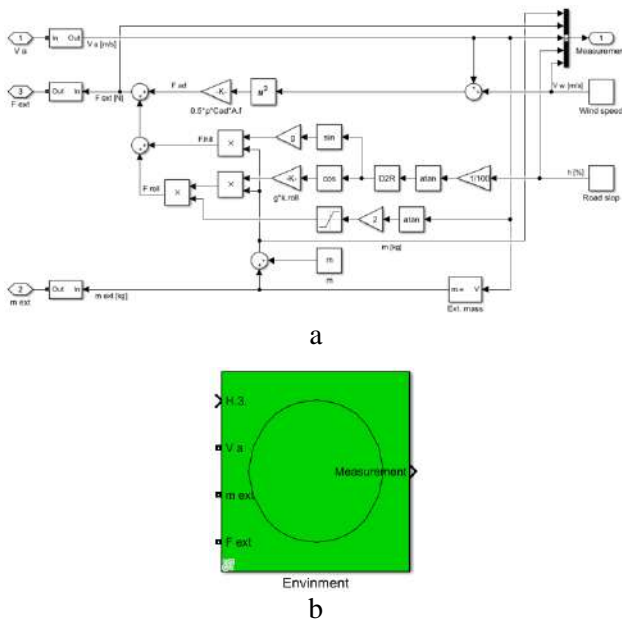

Fig. 6. Simulink model of the environment (a) and its EMR subsystem (b)

Source: compiled by the authors

EMR model of the powertrain of electric bus in Matlab/Simulink environment

The EMR model of the powertrain of the studied electric bus was formed from the developed subsystems in the Matlab/Simulink environment that is shown in Fig. 7.

FORMATION OF TRACTION CHARACTERISTICS OF ELECTRIC BUSES WITH DIFFERENT TRANSMISSIONS

As an object of the study was selected electric bus “Electron E19101” (Fig. 8), the main parameters of which are given in Table 1 [17]. The research technique consists in comparison of energy indicators of movement in a standard transport city cycle of the studied electric bus equipped by the multistage AT with similar indicators of the basic electric bus equipped by the single-stage transmission (without AT).

Table 1. Parameters of the electric bus “Electron E19101”

| Parameter | Value |
|--|-------|
| Chassis parameters: | |
| Equipped mass [kg] | 13560 |
| Total mass [kg] | 19000 |
| Frontal area [m ²] | 9.36 |
| Aerodynamic drag coefficient | 0.5 |
| Rolling resistance coefficient | 0.03 |
| Wheel radius [m] | 0.503 |
| Maximum speed [km/h] | 70 |
| Transmission parameters: | |
| Gear ratio | 9.612 |
| Efficiency | 0.95 |
| Parameters of the converter–motor system: | |
| Maximum mechanical power [kW] | 250 |
| Rated mechanical power [kW] | 189 |
| Maximum torque [Nm] | 1695 |
| Rated torque [Nm] | 990 |
| Maximum angular velocity [rad/s] | 387.5 |
| DC supply voltage [V] | 600 |
| Maximum converter current [A] | 650 |

Source: compiled by the authors

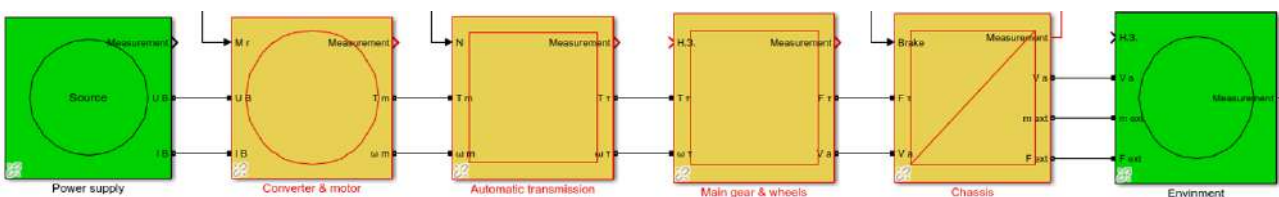

Fig. 7. EMR model of the powertrain of the studied electric bus in Matlab/Simulink environment

Source: compiled by the authors



Fig. 8. Electric bus “Electron E19101”
Source: compiled by the [17]

Selection of automatic transmission

Fig. 9 presents the mechanical characteristics of the electric bus drive with its maximum values of the torque and the angular velocity, which shows that the electric drive system has two-zone angular velocity control.

A necessary and sufficient condition for choosing an AT is that the maximum torque which develops by the engine must be less or equal to the maximum torque of the input shaft of the AT. Based on this, we chose a six-speed AT Allison 3200 with the parameters listed in Table 2 [18].

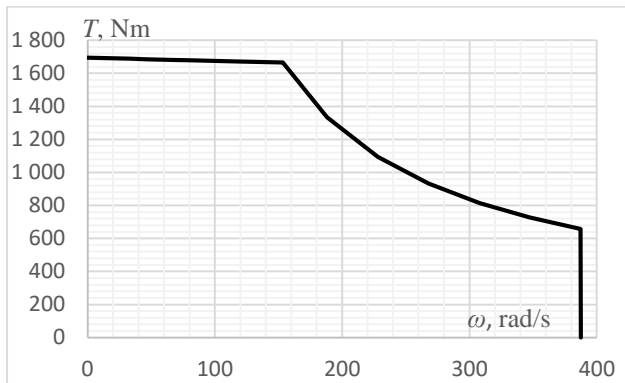

Fig. 9. Mechanical characteristics of the electric bus drive
Source: compiled by the authors

To ensure the intersection the traction characteristics at a constant power region, it is necessary that the output shaft of the gearbox rotate at a higher angular velocity in a lower gear at maximum engine speed than in a higher gear with minimum engine speed at which maximum power is achieved.

The maximum angular velocity of the motor shaft is calculated as follows:

$$\omega_{M,max} = \max_{1 \leq j \leq n-1} (\omega_{M,min}(P_{M,max}) k_s \frac{i_j}{i_{j+1}}), \quad (19)$$

where $\omega_{M,min}(P_{M,max})$ is the minimum angular velocity of the shaft at which the motor develops maximum power; $k_s = 1.2$ is the stock ratio; i is the gear ratio; n is the number of transmission stages, and j is the transmission number.

Table 2. The main parameters of the AT Allison 3200

| Parameter | Value |
|---|-------|
| Gear ratio: | |
| 1-th gear | 3.49 |
| 2-d gear | 1.86 |
| 3-d gear | 1.41 |
| 4-th gear | 1.0 |
| 5-th gear | 0.75 |
| 6-th gear | 0.65 |
| reverse gear | -5.03 |
| main gear | 6.824 |
| Minimum angular velocity of the input shaft [rad/s] | 78.6 |
| Maximum torque of the input shaft [Nm] | 1695 |
| Efficiency | 0.95 |

Source: [18]

From the mechanical characteristics of the electric bus drive (Fig. 9), it is seen that the minimum angular velocity of the shaft at which the motor develops maximum power will be equal to $\omega_{M,min}(P_{M,max}) = 155$ rad/s. After calculating according to expression (19), from the five obtained maximum values, the largest value of the angular velocity of the motor is $\omega_{M,max} = 349$ rad/s, which limits the mechanical characteristics of the motor to this value due to the limitation of the AT.

The traction force developed by the electric bus drive is calculated as follows:

$$F_T = T_M \eta_T \frac{i_j i_g}{r_w}, \quad (20)$$

where i_j is the gear ratio of the AT on the j -th gear.

The speed at which the electric bus moves:

$$V_a = \omega_M \frac{r_w}{i_j i_g}. \quad (21)$$

Based on equations (20) and (21) and the mechanical characteristics of the engine (Fig. 9), taking into account the limitations of the AT, the traction characteristics of the electric bus, which are formed by the drive in different gear stages are developed in Fig. 10.

Fig. 11 shows for comparison the resulting limiting traction characteristic of the studied electric bus with AT and the traction characteristic of the basic version of the electric bus. As can be seen from Fig. 11, with the help of AT, it is possible to expand the traction characteristic, namely to increase the maximum values of the electric bus speed (from 73.5 km/h to 143 km/h) and traction force (from 30.5 kN to 76 kN).

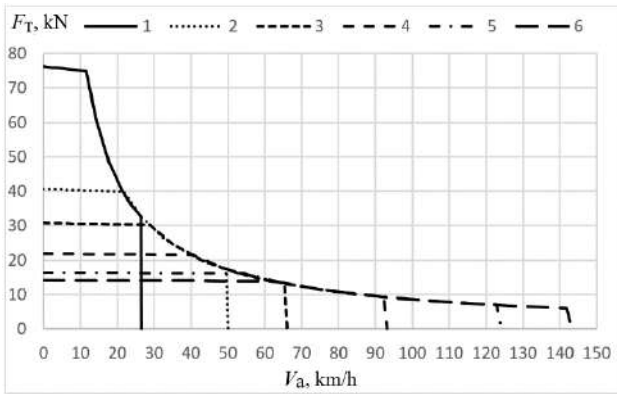

Fig. 10. Traction characteristics of the electric bus drive on different gear stages of the AT
 Source: compiled by the authors

Using the latest values, it is possible to estimate at what maximum inclination a fully loaded electric bus with a small acceleration can move, for example, $a_{min} = 0.5 \text{ m/s}^2$. Based on expressions (13) - (18) we obtain

$$h = 100tg \left(asin \frac{F_{T,max} - m_{\Sigma}(gk_{roll} + a_{min})}{m_{\Sigma}g} \right). \quad (22)$$

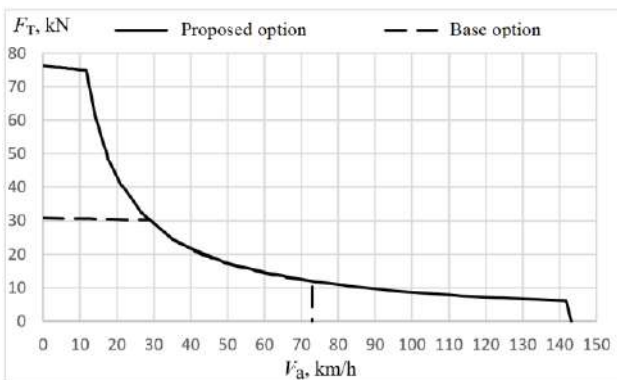

Fig. 11. The resulting traction characteristics of the studied and basic electric buses
 Source: compiled by the authors

Calculations by expression (22) show that the studied electric bus in the first gear can move at a minimum acceleration of 0.5 m/s^2 an inclination of 19 %, and the basic electric bus only at an inclination of 8.3 %.

DEVELOPMENT OF ALGORITHM AND MODEL OF A CONTROL SYSTEM

The main requirement for the traffic control system of the studied and basic electric bus versions is the providing of adjustment of the speed and traction force by the position of the accelerator pedal.

In addition, the following energy strategy is proposed for the studied electric bus: (i) ensuring of the selection of the optimal gear ratio of the AT depending on the actual speed of the electric bus and

the position of the accelerator pedal; (ii) providing of the operation of the converter-motor system with the highest efficiency in all modes of movement of the electric bus.

Traction force forming subsystem

To form the reference of traction force limiting the maximum traction force and speed by the position of the accelerator pedal, it is necessary, for the studied and basic electric buses, to form tables with a family of traction characteristics, which will be within the resulting traction characteristics of drives (Fig. 11). The row numbers of the tables are assigned the value of the speed of the electric bus, and the columns are corresponded to the value of the accelerator pedal position. The cell on which the current values of the accelerator pedal position and speed intersect has the value of the traction force that the drive must create.

Graphical display of the tables created for both variants of the electric buses with traction characteristics of drives for different positions of the accelerator pedal is shown in Fig. 12.

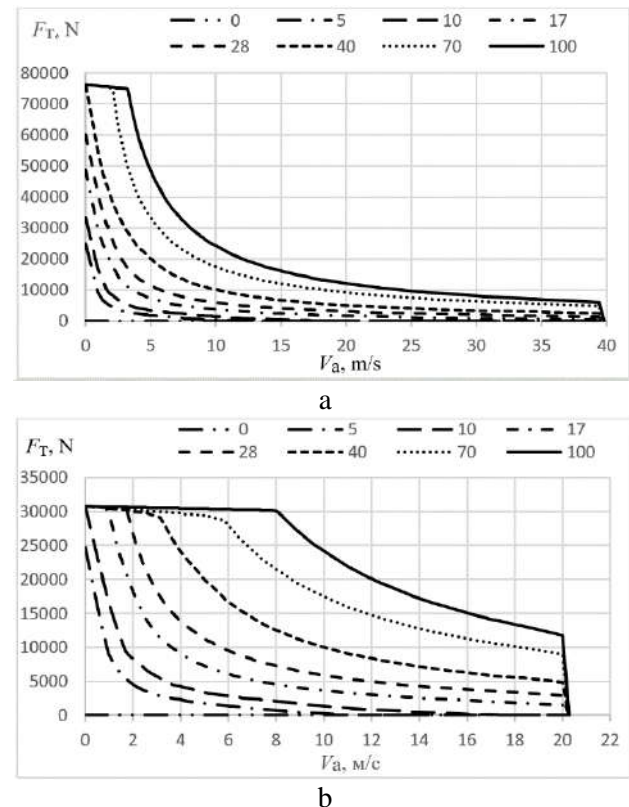

Fig. 12. Formed traction characteristics of the drive for the studied (a) and basic (b) electric buses at different positions of the accelerator pedal (in %)
 Source: compiled by the authors

The limitation of the maximum speed is due to the fact that at a given position of the accelerator

pedal and a given maximum speed, the reference on the traction force is zero. The limitation of the maximum traction force for a given speed is regulated by the position of the accelerator pedal, and accordingly a transition to another traction characteristic is occurred.

A Simulink model of the table (Look-up Table) of traction characteristics allows to carry out an interpolation by various methods between the neighboring values in the table that allows to reduce considerably the amount of data which is necessary for model. In the developed models, the linear interpolation between the neighboring values is applied.

The Simulink model of the traction force subsystem is shown in Fig. 13. To simplify the model, the concept of pseudo-negative position of the accelerator pedal is used, which provides regenerative braking. In fact, the brake pedal regulates regenerative braking. Part of the brake pedal stroke (for example, a range 0 ÷ 30%) is allocated for regenerative braking; mechanical brakes in this range of the pedal position are not imposed. If regenerative braking is not sufficient, then additional application of mechanical brakes occurs if the pedal is transferred to the zone of mechanical braking (for example, a range of 30 ÷ 100 %). A family of traction characteristics reflected along the velocity axis forms the regenerative braking force.

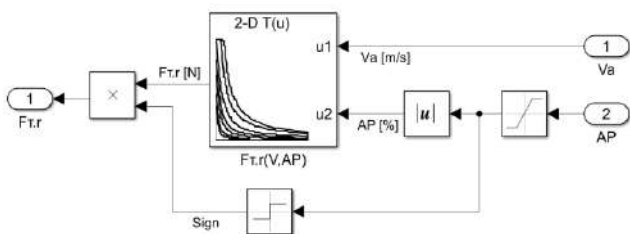

Fig. 13. Simulink model of the subsystem of formation the traction force reference for the electric bus drive

Source: compiled by the authors

Subsystem for selection the optimal gear ratio of the AT

The studied electric bus has the AT with a hydraulic drive. The traction motor drives the hydraulic pump of the transmission. To ensure the required pump performance, a limit on the minimum angular velocity of the motor shaft is introduced. According to (21), this introduces a limit on the minimum speed of the electric bus at which the shift to the next gear will take place. The limitation of the maximum angular velocity of the engine, according to (21), also introduces a limitation on the maximum

speed of the electric bus at which a particular transmission stage can be enabled.

To take into account these limitations, a logic unit has been developed (Fig. 14), which blocks the transmission if the speed of the electric bus is greater than the maximum allowable or less than the minimum allowable for a particular transmission stage. The input information for the unit is the actual speed of the electric bus and the maximum and minimum speeds at which certain transmission stages can be enabled. The output of the unit is the permission to engage certain gears and the command to engage the first gear, if the speed of the electric bus is less than the speed at which the permission to engage the second gear is formed.

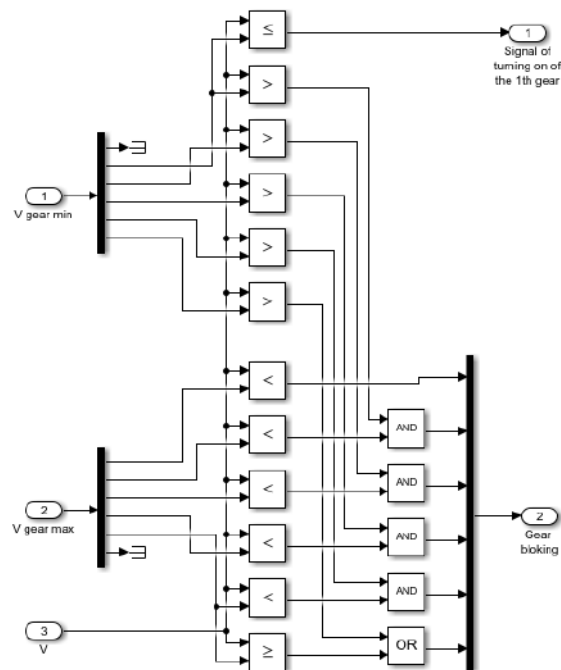

Fig. 14. Model of the blocking a choice of admissible gear stages

Source: compiled by the authors

The model for calculating gear lock settings is shown in Fig. 15. After weeding out gears that are not suitable for this speed mode, only those gears that are suitable for this speed mode remain.

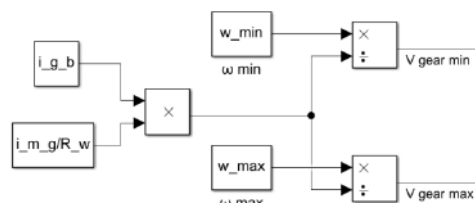

Fig. 15. Model for calculating gear lock settings

Source: compiled by the authors

Based on the traction force signal and the current speed of the electric bus, expressions (20) and (21) for each gear determine the torque and

angular velocity of the motor shaft, and then use the energy efficiency table to calculate the drive efficiency values for each gear. For these purposes, a subsystem for calculating the efficiency of the electric drive was developed, which is shown in Fig. 16. The main element of this subsystem is the table of power efficiency of the converter–motor system, which is usually obtained experimentally.

For the traction electric drive of the electric bus, the efficiency values depending on the electromagnetic torque and the angular velocity of the motor are shown in Fig. 17 in the form of an energy efficiency map, in which the efficiency is represented by isoclines. For further application of this map in the Simulink model, the values of the drive efficiency for the grid of specific values of the electromagnetic torque and angular velocity of the motor are obtained by interpolation. They are entered to the Look-up Table $\eta(\omega_M, T_M)$ shown in Fig. 16.

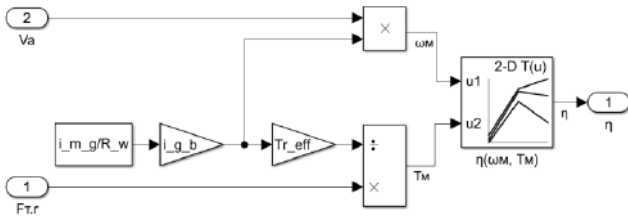

Fig. 16. Model of the unit for calculation the efficiency of electric motor
Source: compiled by the authors

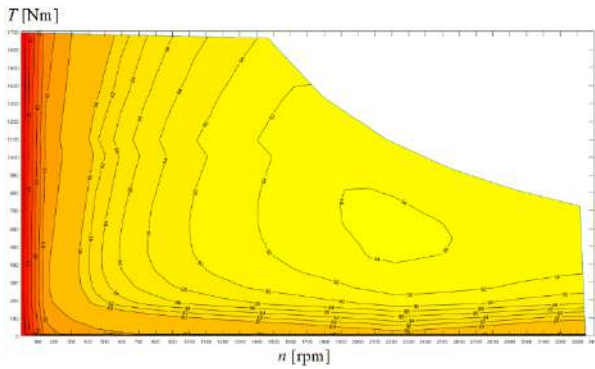

Fig. 17. Efficiency map of the converter–motor system
Source: compiled by the authors

Based on the information from the units of selection of allowable gears and the calculation of the drive efficiency, using the gearshift unit, the selection of the most efficient transmission stage occurs. Fig. 18 shows the algorithm of the gearshift unit operation. To improve stability and reduce the number of switches, a hysteresis was introduced. Transmission shifts occur only when the efficiency of the next transmission stage is greater than the current by 0.25 %. The value of the hysteresis was selected based on the evaluation of the behavior of the electric bus model during the simulation.

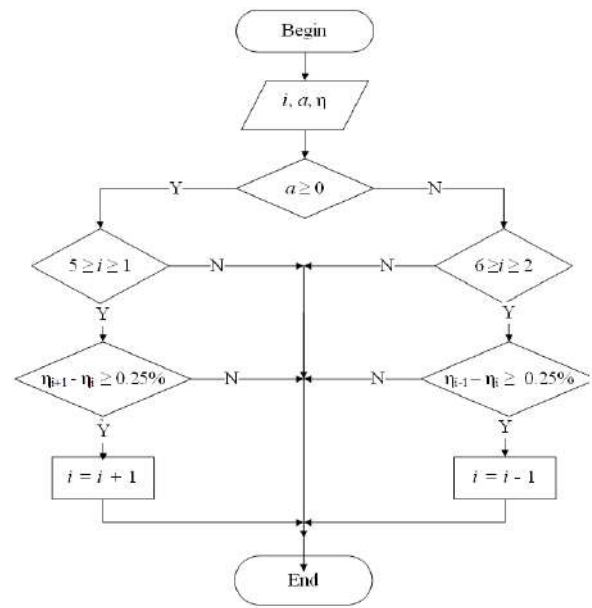

Fig. 18. Algorithm of operation of the gearshift unit

Source: compiled by the authors

Prediction of the next gear stage is based on the acceleration of the electric bus. If the acceleration is positive or equal to zero, then the shift is sequentially in the direction of increase. If the acceleration is negative, then the gear is shifted sequentially in the direction of reduction.

The structure of the created in the Simulink environment subsystem for selecting the optimal gear ratio of the AT and the relationships between its functional units is shown in Fig. 19.

Motor torque generation subsystem

Simulink model of the subsystem is shown in Fig. 20. Based on the information about the enabled transmission and the traction force signal, the subsystem generates a reference signal for the motor torque based on equation (20).

Based on the developed subsystems, the Simulink model of the all control system was created as is shown in Fig. 21.

Since, for the basic version of electric bus, the gear ratio is constant, the control system is much simpler. Its structure is shown in Fig. 22.

The transport cycle model simulates the movement of an electric vehicle. The standard urban motion cycle EPA Federal Test Procedure (FTP-75) [19], which is in the library of new versions of Simulink, was chosen for modeling. This cycle is designed to study the energy performance of urban passenger cars and electric vehicles, as well as light trucks. In this study, this cycle is adapted to simulate the movement of electric buses; in particular, 1.5 times reduced speed profile (speed in miles per hour

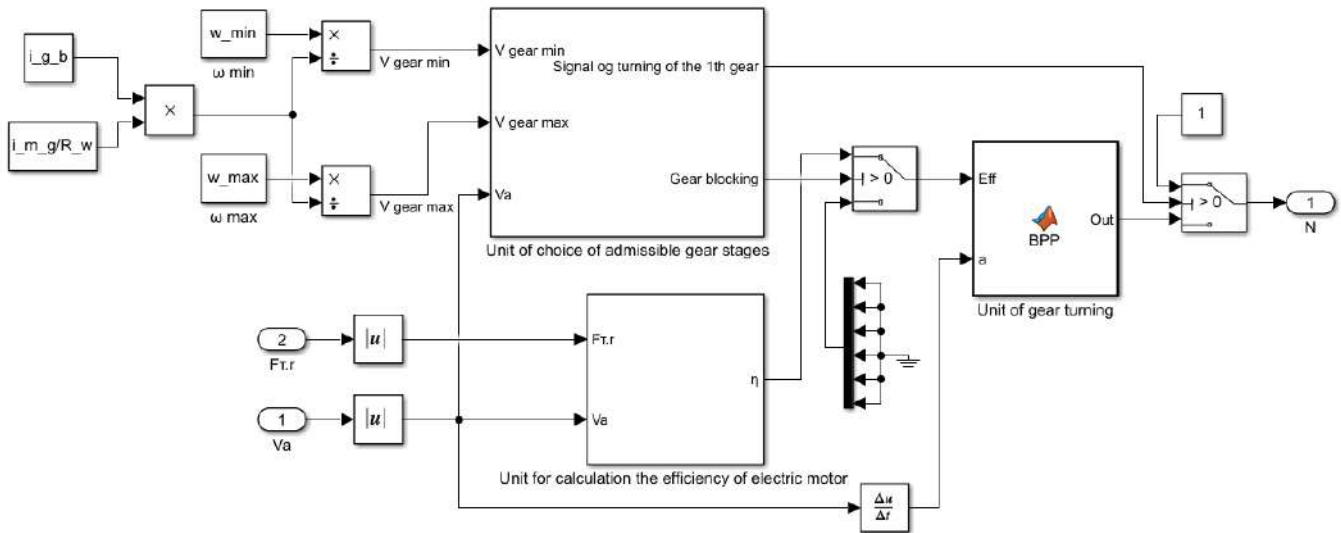

Fig. 19. Simulink model of the subsystem of selection the optimal gear ratio of the AT

Source: compiled by the authors

is taken as the speed in km/h). This reduced the average speed along the route (19.4 km/h) and acceleration during starting and braking. In the simulation, there was a change in the total weight of the electric bus due to the change in the number of passengers during stops. In addition, in order to reproduce the real operating conditions, it is possible to set a wind speed, which value and direction can be variable according to the required law, and the slope of the road (see Fig. 6).

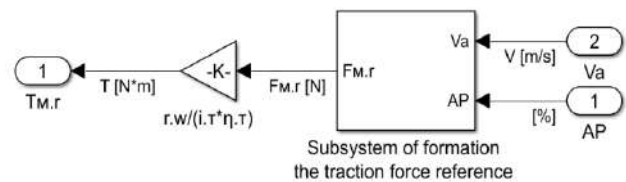

Fig. 22. The structure of the drive control system for the basic electric bus

Source: compiled by the authors

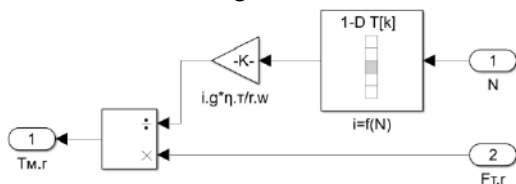

Fig. 20. Model of the motor torque generation subsystem

Source: compiled by the authors

As a driver of the electric bus, there is the Simulink model of the transport cycle, which sets the speed of the electric bus (Fig. 24). A proportional speed controller with a coefficient of 200 compares the reference and real speeds of the electric bus.

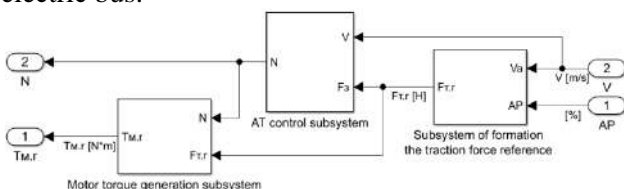

Fig. 21. The structure of the drive control system of the studied electric bus

Source: compiled by the authors

SIMULATION RESULTS

Based on the developed Simulink models of the powertrain of the electric bus (Fig. 7) and control systems (Fig. 21 and Fig. 22), the EMR models of the electric buses for the studied and basic options are developed and shown in Fig. 23.

The results of parallel simulation of the studied and basic variants of the electric buses in the test transport cycle are presented in Fig. 25, Fig. 26 and Fig. 27.

As can be seen from Fig. 25a, for both variants of transmissions, the electric drive system accurately works out the profile of movement speed of the electric buses set by the driver (transport cycle) which during this cycle pass a distance of 7.37 km (Fig. 25b). Fig. 25c shows how the external load mass of electric buses changed during the transport cycle simulating the flow of passengers on the route. To perform this movement at a given load, the drives of electric buses in both options formed a traction force, the time dependence of which is shown in Fig. 25d.

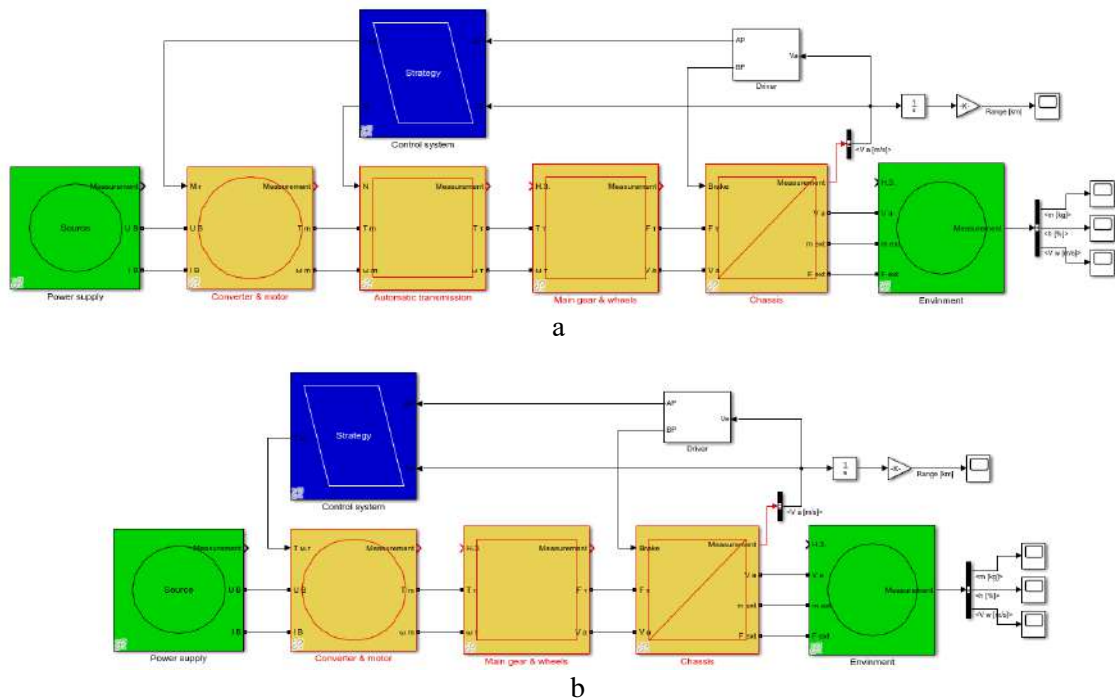

Fig. 23. EMR models of electric buses for the studied (a) and basic (b) options created in the Matlab/Simulink environment

Source: compiled by the authors

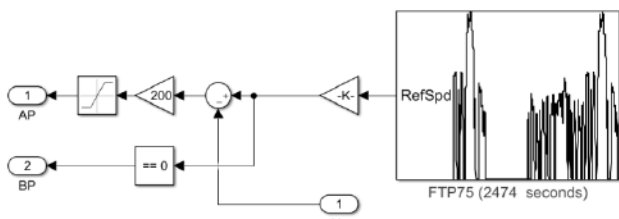

Fig. 24. Simulation model of the driver

Source: compiled by the authors

As a result of operation of the control system of multistage AT according to the algorithm shown in Fig. 18, the numbers of gear stage of the AT changed during the transport cycle as shown in Fig. 26a. The time diagrams in Fig. 26b and Fig. 26c show the changes of angular velocity and electromagnetic torque of the motors in two buses. As can be seen from these diagrams, the use of multistage AT significantly reduces the ranges of changes in angular velocity and electromagnetic torque of the traction motor during the transport cycle. This ensures the predominant operation of the electric drive in the zone of higher efficiency values, as shown in Fig. 26d. A significant difference between the compared options of transmissions was observed better in a time interval of 350-650 s when the electric buses were moved at high speed. This is especially evident from the fragment of the latter time diagram shown in Fig. 27.

As a result of the simulation during the time of movement in the transport cycle, the electric drives of the studied and basic buses consumed slightly different amounts of energy from the on-board battery (Fig. 26e) – 12.68 kWh and 13.12 kWh, respectively. Therefore, the energy benefit from the use of a multi-stage AT in this simulation was about 3.35 %, which is a positive result, but not significant enough. This is explained, first, by the specifics of the applied transport cycle, in which electric buses moved mainly at a speed of 25-40 km/h (Fig. 25a). As can be seen from the map of the energy efficiency of the converter–motor system (Fig. 17), the decrease in the efficiency of the electric drive is significant at low angular velocities of the motor at all values of the electromagnetic torque, and at high angular velocities at low values of the torque.

The electric motor in the basic electric bus version with a single-stage transmission will work in these low-efficiency modes during a start and acceleration of the bus, as well as its movement at high speeds. At the same time, the use of AT in the studied version of the electric bus allows the electric motor to work in these modes with average angular speeds and, accordingly, with high efficiency. Since starting, acceleration and increase speeds in the urban cycle are not long-lasting, therefore, the energy effect of the studied electric bus with the multistage transmission did not a noticeable.

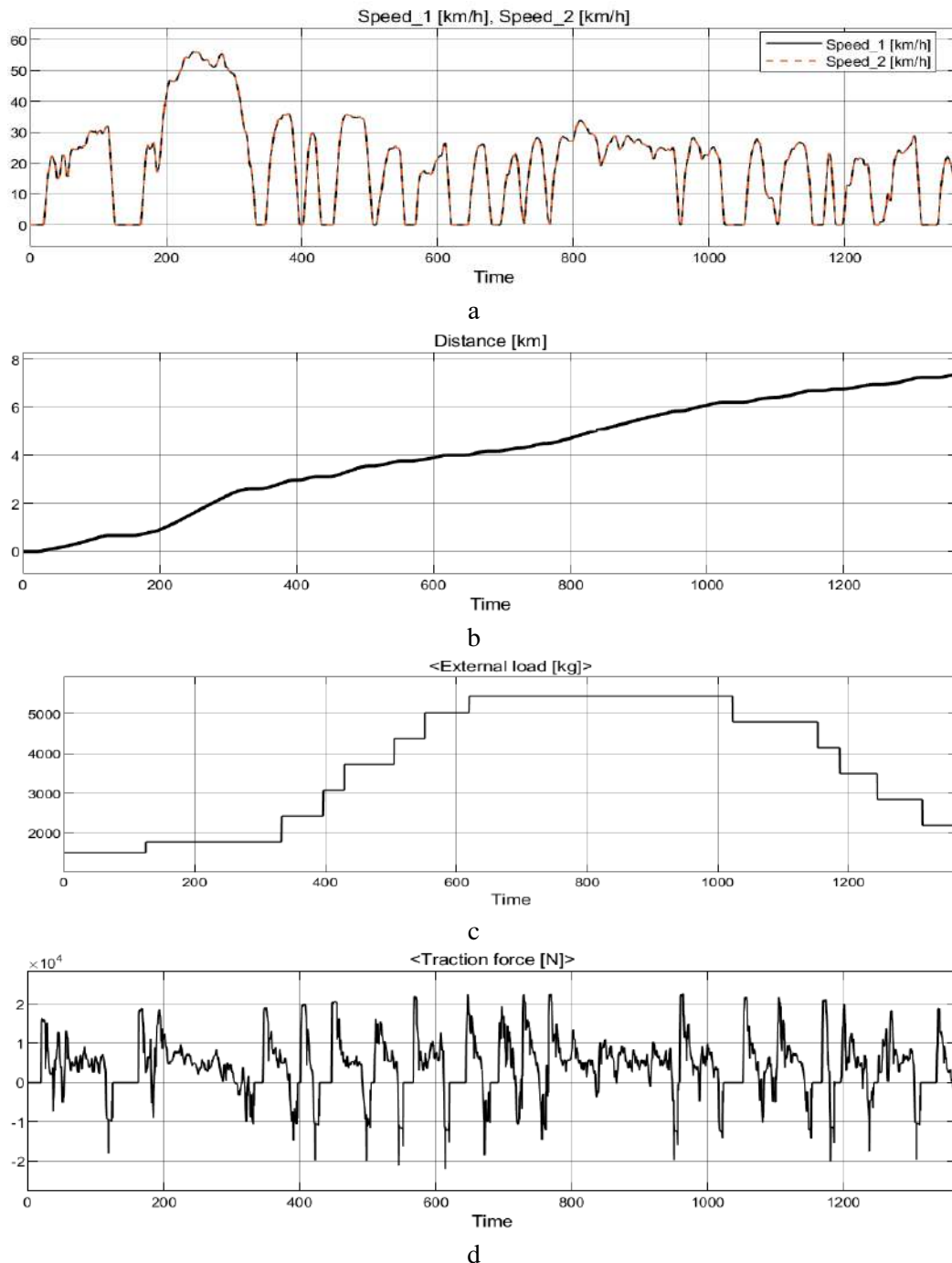

Fig. 25. Time diagrams of the main variables during the simulation of electric buses movement in the transport cycle (1 – studied variant; 2 – basic variant):

- a) set by the driver and performed during simulation the speed of electric buses for both variants; b) the distance traveled by electric buses during the transport cycle; c) change of the total external weight of electric buses during the transport cycle; d) traction force of electric buses**

Source: compiled by the authors

However, in today's traffic-laden city, there is frequent and prolonged movement at crawling speeds. In such cases, the energy advantage of using the multistage AT will be high. To confirm this, the movement of two compared electric buses was simulated in a similar to the applied transport cycle FTP-75, but with a five-fold reduced speed of movement, which can be seen from the time diagram

shown in Fig. 28a. At the same time, the average driving speed for this cycle also decreased five times and amounted to 3.88 km/h. As can be seen from Fig. 28b, the amount of electric energies consumed per cycle by the studied and basic electric buses from their batteries were 2.75 kWh and 2.905 kWh, respectively, which provides an energy gain in the studied version by 5.3 %.

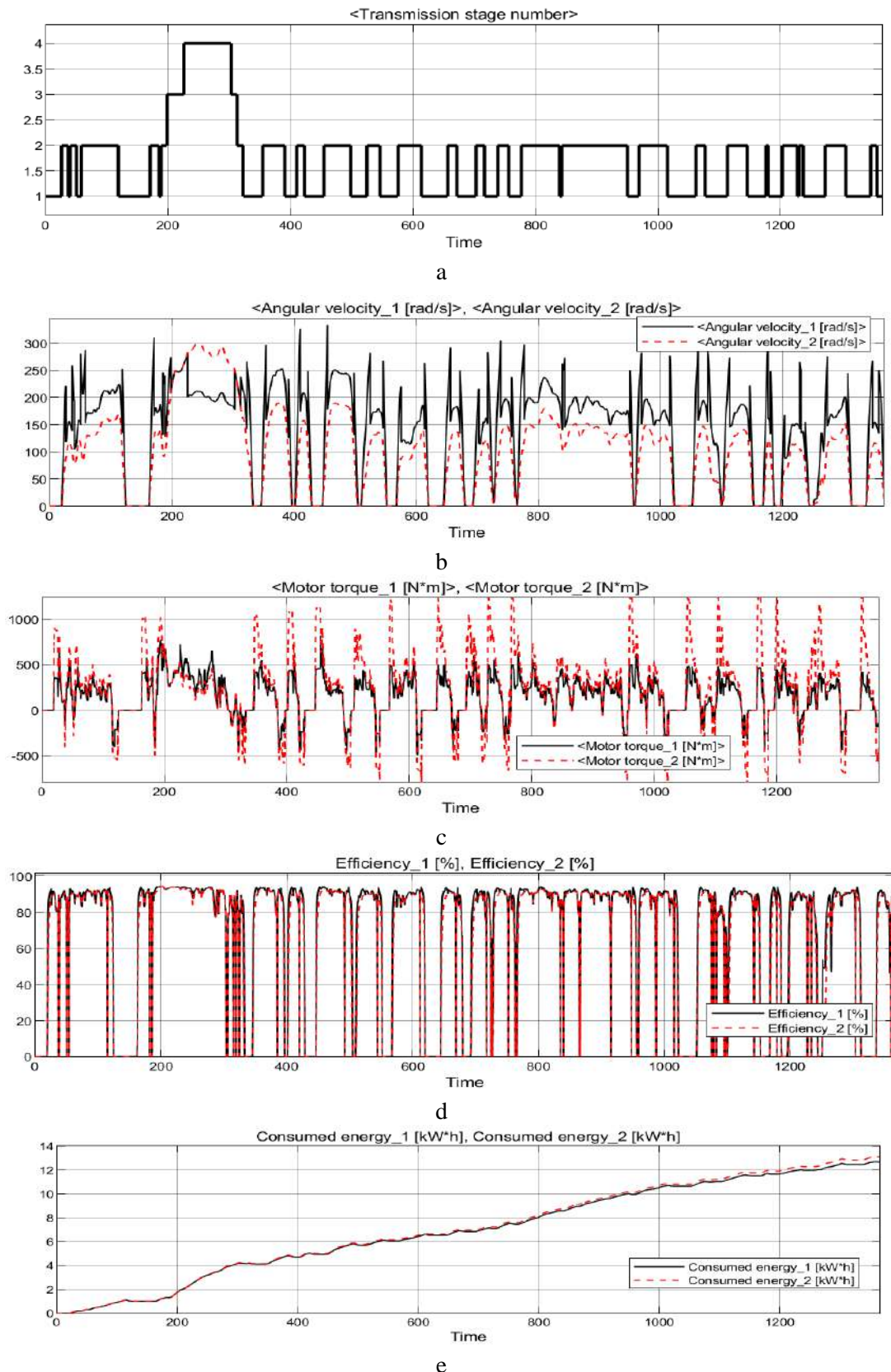

Fig. 26. Time diagrams of main variables during the simulation of electric buses movement in the transport cycle (1 – studied variant; 2 – basic variant):
a) AT stage numbers; b) motor angular velocity for two variants of busses; c) motor electromagnetic torque for two variants of busses; d) drive efficiencies for both options; e) electricity consumed from the battery to perform the cycle for both cases

Source: compiled by the authors

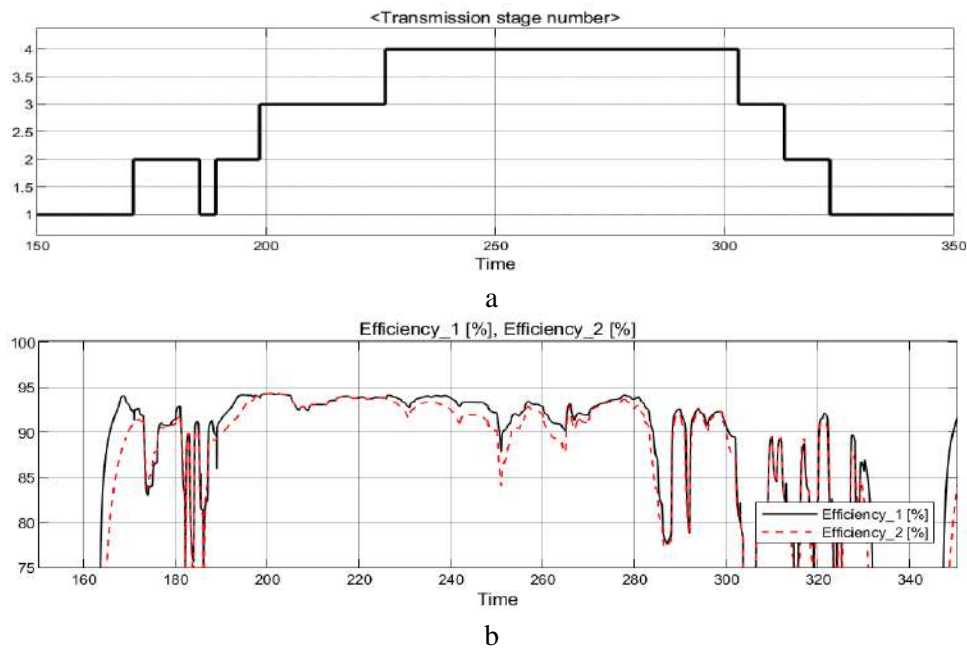

Fig. 27. Fragment of the diagrams of gear shifting (a) and drive efficiency (b) for both options of bus transmission

Source: compiled by the authors

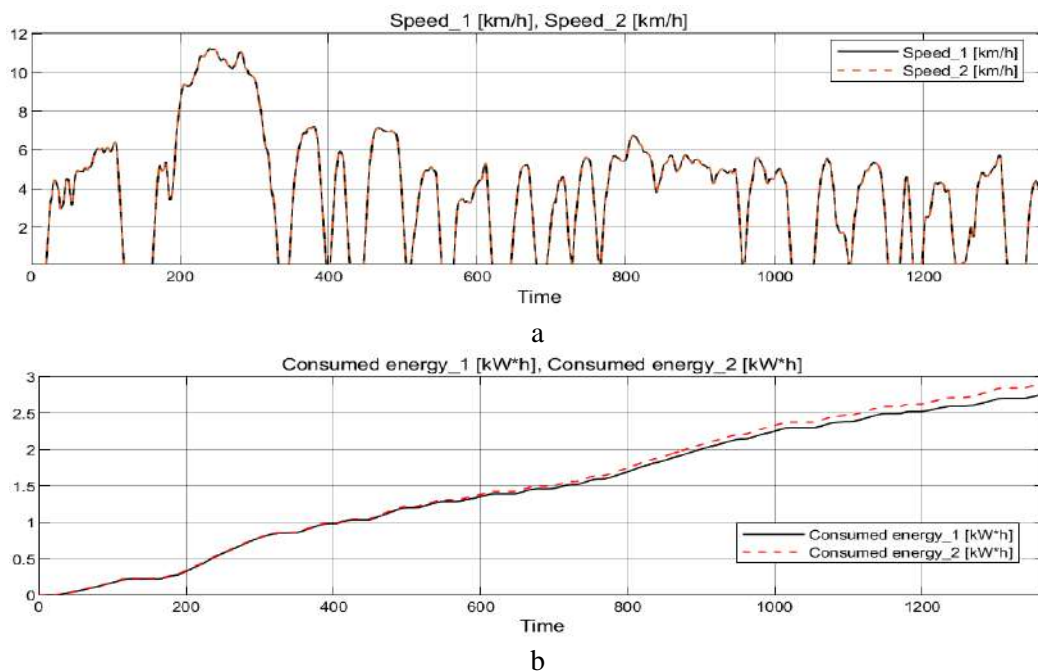

Fig. 28. Time diagrams of the AT stage numbers (a) and electricity consumed from the battery to perform the cycle for both options of bus transmission (b) for the case of reducing the speed of the buses by 5 times

Source: compiled by the authors

CONCLUSIONS

Based on the research results, the following conclusions can be made.

1. In this work, the calculation of the parameters of the drive was carried out and the mathematical model of the powertrain of the electric bus by the method of EMR as well as the control systems of AT and motor drive were developed.

Based on the mathematical model in the MATLAB/Simulink environment, the works in the city transport cycle of electric buses with two transmission variants were investigated – the studied one with the multistage AT and the basic one with the single-stage transmission.

2. The strategy of control of transmission with AT for the studied electric bus provides work of the electric motor with the maximum possible efficiency

in all modes of movement of the electric bus. However, a significant increase in energy efficiency in the urban traffic cycle was not recorded due to the specifics of the applied transport cycle. The energy advantage of multispeed transmission is manifested in frequent starts and prolonged driving at low speeds, which occurs in modern congested cities, as well as in high-speed traffic on bypass roads in cities and suburban traffic.

3. The use of a multistage AT allows to use electric motor of a much lower power to provide the

required traction and expanding its limits in both directions: towards increase in maximum traction force, which allows to easily move a fully loaded bus at a high slope; towards a significant increase in maximum speed. This can be especially useful for mountain bus applications and for long-distance transport.

4. The disadvantage of the studied electric bus with a multistage AT is the complexity of design and increase in cost.

REFERENCES

1. Borén, S. “Electric buses’ sustainability effects, noise, energy use, and costs”. *Int. Journal of Sustainable Transport*. 2020; Vol. 4(12): 956–971. DOI: <https://doi.org/10.1080/15568318.2019.1666324>.
2. Mahmoud, M., Garnett, R., Ferguson, M. & Kanaroglou, P. “Electric buses: A review of alternative powertrains”. *Renewable and Sustainable Energy Reviews*. 2016; Vol.62(C): 673–684. DOI: <https://doi.org/10.1016/j.rser.2016.05.019>.
3. Kumar, L. & Jain, S. “Electric propulsion system for electric vehicular technology: A review”. *Renewable and Sustainable Energy Reviews*. 2014; Vol.29C: 24–940. DOI: <https://doi.org/10.1016/j.rser.2013.09.014>.
4. Skouras, T. A., Gkonis, P. K., Ilias, C. N., Trakadas, P. T., Tsampasis, E. G. & Zahariadis, T. V. “Electrical vehicles: current state of the art, future challenges, and perspectives”. *Clean Technologies*. 2020; Vol.2: 1–16. DOI: <https://doi.org/10.3390/cleantechnol2010001>.
5. Nazarova, O. S., Osadchyy, V. V. & Brylysty, V. V. “Computer simulation of electric vehicle acceleration processes with different positions of the mass center”. *Applied Aspects of Information Technology*. 2020; Vol.3 No.3: 154–164. DOI: <https://doi.org/10.15276/aait.03.2020.4>.
6. Sornioti, A., Pilone, G. L., Viotto, F., Bertolotto, S., Everitt, M., Rob Barnes R. & Morrish, I. “A Novel seamless 2-speed transmission system for electric vehicles: Principles and simulation results”. *SAE Int. Journal of Engines*. 2011; Vol.4: 2671–2685. DOI: <https://doi.org/10.4271/2011-37-0022>.
7. Zhang, Z., Zuo, C., Hao, W., Zuo, Y., Zhao, X.L., Zhang, M. et al. “Three-speed transmission system for purely electric vehicles”. *Int. Journal of Automotive Technology*. 2013; Vol.14: 773–778. DOI: <http://doi.org/10.1007/s12239-013-0085-0>.
8. Niu, O., Hao, H. & Yang R. “Research on automatic manual transmission of pure electric vehicle”. *OP Conf. Series: Materials Science and Engineering*. IOP Publishing. 2020; Vol.825. DOI: <http://doi.org/10.1088/1757-899X/825/1/012005>.
9. Gokce, K. “Performance evaluation of a newly designed robotized gearbox for electric city buses”. *Mechanika*. 2017; Vol. 23(5): 639–645. DOI: <https://doi.org/10.5755/j01.mech.23.5.14060>.
10. Ling, L., Chen, Z.-s. & Luo, Y.-y. “Study on control process of automatic mechanical transmission system for pure electric bus”. *Applied Mechanics and Materials*. 2012; Vols. 220–223: 1795–1799. DOI: <http://doi.org/10.4028/www.scientific.net/AMM.220-223.1795>.
11. Zhang, Z. S., Xiao, H. J., Yang, C. F., Ling, L. & Wu, B. H. “The synchronous control of automated manual transmission in three-gear electric bus”. *Applied Mechanics and Materials*. 2013; Vol. 419: 731–734. DOI: <http://doi.org/10.4028/www.scientific.net/AMM.419.731>.
12. Abdel-Halim, N. A. “Use of Vehicle Power-train simulation with AMT for fuel economy and performance”. *Modern Mechanical Engineering*. 2013; Vol.3: 127–135. DOI: <http://doi.org/10.4236/mme.2013.33018>.
13. Chen, K., Bouscayrol, A., Berthon, A., Delarue, P., Hissel, D. & Trigui, R. “Global modeling of different vehicles using Energetic Macroscopic Representation”. *IEEE Vehicle Power and Propulsion Conf*. Harbin: China. 3-5 Sept. 2008. p. 533–539. DOI: <http://doi.org/10.1109/VPPC.2008.4677728>.
14. Shchur, I., Kasha, L. & Bukavyn, M. “Efficiency evaluation of single and modular cascade machines operation in electric vehicle”. *2020 IEEE 15th Int. Conf. on Advanced Trends in Radioelectronics, Telecommunications and Computer Engineering (TCSET)*. Lviv-Slavske: Ukraine. 25-29 Febr. 2020. p.156–161. DOI: <http://doi.org/10.1109/TCSET49122.2020>.
15. Shchur, I., Havdo, I. & Biletskyi, Y. “Modeling of two-motor front-wheel drive control for electric vehicle with electronic differential based on Energetic Macroscopic Representation”. *Energy Engineering and Control Systems*. 2020; Vol.6 No.1: 51–60. DOI: <http://doi.org/10.23939/jeecs2020.01.051>.
16. “EMR Website. Energetic Macroscopic Representation”. – Available from: <http://www.emrwebsite.org/energetic-macroscopic-representation.html>. – [Accessed March 2020].

17. “Electric bus Electron E19101”. – Available from: https://uk.wikipedia.org/wiki/%D0%95%D0%BB%D0%B5%D0%BA%D1%82%D1%80%D0%BE%D0%BD_%D0%9519101. – [Accessed Jan 2020].

18. “Allison Transmission 3000/3200 Series”. – Available from: [https://www.allisontransmission.com/docs/default-source/specification-sheets/int3000_sa5341\(201306\)blk.pdf?sfvrsn=2](https://www.allisontransmission.com/docs/default-source/specification-sheets/int3000_sa5341(201306)blk.pdf?sfvrsn=2). – [Accessed Feb 2020].

19. “Dynamometer drive schedules”. – Available from: <https://www.epa.gov/-vehicle-and-fuel-emissions-testing/dynamometer-drive-schedules>. – [Accessed April 2020].

Conflicts of Interest: the author declare no conflict of interest

Received 26.10.2020

Received after revision 14.01.2021

Accepted 11.03.2021

DOI: <https://doi.org/10.15276/aait.05.2022.9>

УДК 621.233 + 629.113.65 + 519.87

Оптимізація керування автоматичною багатоступінчастою трансмісією міського електроавтобуса

Щур Ігор Зенонович¹⁾

ORCID: <https://orcid.org/0000-0001-7346-1463>; ihor.z.shchur@lpnu.ua. Scopus Author ID: 36348908300

Ковтун Вячеслав Олександрович¹⁾

ORCID: <https://orcid.org/0000-0003-2970-0994>; viacheslav.kovtun.mnee.2020@lpnu.ua

¹⁾ Національний університет «Львівська політехніка», вул. С. Бандери, 12. Львів, 79013, Україна

АНОТАЦІЯ

Загрозлива екологічна ситуація в сучасних перевантажених транспортних містах зумовлюють доцільність заміни в транспортних перевезеннях автобусів з дизельними двигунами електроавтобусами. З метою підвищення енергетичної ефективності роботи привода електроавтобуса та розширення завдяки цьому його запасу ходу, у роботі досліджується доцільність застосування багатоступінчастої автоматичної трансмісії. Для досліджень було взяти електроавтобус «Електрон Е19101» та розглянуто два його варіанти: дослідний з шестиступінчастою автоматичною коробкою перемикачів передач (АКПП) та базовий з одноступінчастою трансмісією. Для кожного з варіантів сформовано тягові характеристики електропривода для різних положень педалі акселератора. Порівняльні дослідження роботи обох варіантів електроавтобуса проведено шляхом комп'ютерного моделювання. Для цього за методом Energetic Macroscopic Representation (EMR) середовищі Matlab/Simulink побудовано комп'ютерні моделі усіх підсистем електроавтобусів, а також зовнішніх впливів, що чинять опір рухові та визначають навантаження на систему електропривода. Застосування вказаного методу дає змогу провести симулювання руху двох варіантів електроавтобуса за час тривалого адаптованого до його руху стандартного міського транспортного циклу FTP-75. Для дослідного варіанту розроблено систему керування АКПП з метою поточного вибору оптимального значення передавального числа коробки передач, за якого отримується максимальне значення ККД системи електропривода в конкретних умовах руху. Результати досліджень показали перевагу на 3,35 % в енергетичних затратах на рух в застосованому транспортному циклі багатоступінчастої трансмісії над одноступінчастою. Проте, як показано окремим дослідженням, ця перевага зростає до 5,3% за частих рушань і тривалого руху електроавтобуса на низьких швидкостях, що має місце в сучасних перевантажених транспортних містах. Крім того, застосування АКПП дає змогу знизити номінальну потужність двигуна електроавтобуса, збільшити його максимальне тягове зусилля, що забезпечить можливість рушання за повного завантаження під великий ухил, а також значно збільшити максимальну швидкість руху, що є важливим для замських перевезень.

Ключові слова: електроавтобус; автоматична багатоступінчаста трансмісія; оптимізація керування; коефіцієнт корисної дії; Energetic Macroscopic Representation (EMR)

ABOUT THE AUTHORS



Ihor Z. Shchur – D.Sc. (Eng), Professor, Head of Department of the Electromechanics and Computerized Electromechanical Systems. Lviv Polytechnic National University, 12, S. Bandera Str. Lviv, 79013, Ukraine
ORCID: <https://orcid.org/0000-0001-7346-1463>; ihor.z.shchur@lpnu.ua. Scopus Author ID: 36348908300

Research field: Control systems of vehicle electric drive; renewable energy; energy storage systems; energy-based mathematical modeling and synthesis of control systems

Щур Ігор Зенонович - доктор технічних наук, професор, зав. каф. Електромехатроніки і комп'ютеризованих електромеханічних систем Національного університету «Львівська політехніка», вул. С. Бандери, 12. Львів, 73013, Україна



Viacheslav O. Kovtun - graduate student of Department of the Electromechanics and Computerized Electromechanical Systems. Lviv Polytechnic National University, 12, S. Bandera Str., Lviv, 79013, Ukraine
ORCID: <https://orcid.org/0000-0003-2970-0994>; viacheslav.kovtun.mnee.2020@lpnu.ua

Research field: Vehicle electric drive; control systems; power electronics

Ковтун Вячеслав Олександрович - випускник магістратури кафедри Електромехатроніки і комп'ютеризованих електромеханічних систем Національного університету «Львівська політехніка», вул. С. Бандери, 12. Львів, 73013, Україна